





FORCE 50 and INTEG 50 Robotic Nozzle system







Generic installation and
Setup manual













UNIFIRE

WARNINGS

 WARNING	<p>READ this instruction manual in its entirety prior to installing, maintaining, or using the Unifire Force™ ROBOTIC NOZZLE (AKA "Robotic nozzle" or "CANNON").</p> <p>Failure by any installer, maintenance personnel or operator to receive proper training, including reading and understanding this manual, prior to its use constitutes misuse of the equipment and could result in serious bodily injury or death and/or damage to the robotic nozzle or other property. Only qualified and trained professionals who are familiar with this equipment and general safety procedures may operate the Force robotic nozzle.</p> <p>The purpose of this Manual is to provide all users, installers, and maintenance personnel with the relevant information concerning the design, proper use, installation and maintenance of the equipment and should be read and made available to all such persons. This Manual will help prevent danger and injury to you and others. If you would like further copies of this manual, ask Unifire or download it at www.unifire.com. If you have any questions relating to this equipment and its safe use please contact Unifire prior to use at: Support@unifire.com</p>
 WARNING	<p>DO NOT ATTEMPT TO MODIFY THIS EQUIPMENT IN ANY WAY. Modification of the equipment may result in damage to, or malfunction of, the equipment, which could lead to serious injury of the operator and/or others. Internal inspection, maintenance and repairs should only be performed by, or under the specific, express authority of Unifire AB.</p>
 WARNING	<p>NEVER POINT THE FORCE 50 OR ANY Robotic nozzle DIRECTLY AT HUMANS WHILE WATER IS SPRAYING THROUGH IT, as doing so can result in serious injury or possibly death. The FORCE 50 is capable of directing flows of up to approximately 2000 liters per minute (540 gallons per minute) at pressures of up to 12 bars (175 psi) and has a maximum throwing range of up to approximately 65 meters (70 yards). Such forces are very dangerous and capable of producing serious injury or death to persons and serious damage to property. They are also capable of throwing objects with extreme force and velocity into other objects or persons. Accordingly, only professional, trained firefighters or other qualified individuals may operate this equipment after being thoroughly familiar with the Manual, and always by exercising extreme caution to avoid hitting people or lose objects with the water (or other fluid) stream.</p>
 WARNING	<p>BE SURE THAT THE ROBOTIC NOZZLE IS TIGHTLY AND PROPERLY SECURED AT ALL TIMES DURING OPERATION! Serious injury or death can occur if the robotic nozzle is not fully and properly secured and supported. Be sure that the mounting pipe for the FORCE 50 robotic nozzle is capable of withstanding a nozzle reaction force of at least eight thousand (8,000) Newtons (800 kgf). The FORCE 50 robotic nozzle should not be used on a portable stand of any kind, as such use can be extremely dangerous and can result in Serious Injury or Death.</p>

 WARNING	<p>The FORCE 50 IS HEAVY. Use caution and assistance when installing and take care to avoid injury to your back. Seek assistance to help support and twist the robotic nozzle during installation and take care to avoid injury to your back during handling and installation.</p>
 WARNING	<p>NEVER USE THE ROBOTIC NOZZLE AT PRESSURES HIGHER THAN 12 BARS (175 PSI). The maximum operating pressure for the FORCE 50 robotic nozzle is 12 bars (175 psi). Use of the FORCE 50 at pressures higher than 12 bars is dangerous and can lead to serious injury or death or may damage the robotic nozzle. Moreover, the recommended operating pressure of the FORCE 50 is between 7 and 8 bars (100 and 115 psi), which also will provide optimal performance.</p>
 WARNING	<p>ONLY MOUNT THE FORCE Robotic nozzle SO THAT ITS BASE IS PERPENDICULAR TO THE GROUND. DO NOT install the robotic nozzle at an angle or upside-down without the specific prior written consent of Unifire AB. Doing so may cause damage to the robotic nozzle gears and motors, which could lead to malfunction.</p>
 WARNING	<p>FOLLOW ALL MAINTENANCE & INSPECTION PROCEDURES in this manual.</p>
 WARNING	<p>Be sure to use the proper type and size of threads at the robotic nozzle base and also between the robotic nozzle and nozzle (if using a nozzle not supplied by Unifire specifically for use with this robotic nozzle). Use of the wrong type or size of threads will result in an improper connection which can cause leaking and also may cause the robotic nozzle and/or nozzle to dislodge under high pressure, possibly leading to serious injury or death to persons and/or serious damage to property. If you have any doubts as to the exact thread supplied by Unifire, contact Unifire for clarification prior to connecting the robotic nozzle and nozzle.</p>
 WARNING	<p>KEEP A SAFE DISTANCE DURING OPERATION AND MOVEMENT. The FORCE 50 Robotic nozzle has moving parts. Be sure to keep a safe distance from the robotic nozzle as it moves and keep hands and fingers away from pinch points to avoid injury.</p>
 WARNING	<p>AVOID RAPID CHARGING. Rapid charging of the robotic nozzle is potentially dangerous and can cause serious injury to persons and/or property and may cause damage to the robotic nozzle. Charge the robotic nozzle slowly to avoid creating a potentially dangerous, high-pressure surge.</p>

 WARNING	<p>USE ONLY UNIFIRE-APPROVED NOZZLES / NOZZLE TIPS. The FORCE 50 was designed for use with the Unifire INTEG 50 and Unifire Smooth Bore nozzles. Use of any nozzle other than a Unifire nozzle made for the FORCE 50 without specific, written approval in advance by Unifire AB constitutes misuse of the product and could affect the safety, performance and/or operation of the robotic nozzle. Such malfunctions could also result in the nozzle coming loose and being rapidly ejected with high force, which could cause serious injury or even death.</p>
 WARNING	<p>DO NOT OPERATE IN EXPLOSIVE ZONES OR ENVIRONMENTS! The electric motors and other components are potential ignition sources and could spark ignition if used in explosive environments. The FORCE 50 is not approved for operation in explosive environments and therefore it should never be used in such environments.</p>
 WARNING	<p>DO NOT IMMERSE EQUIPMENT IN WATER. Do not immerse the robotic nozzle, its control box (the TARGA PLC) nor the joystick in water and be sure to keep water out of their interiors. Unifire's robotic nozzles, and joystick are designed to withstand moderate exposure to rain and water splashing during normal use of the robotic nozzle. Prolonged or extreme exposure to water, including submersion, however, will cause damage and could also cause electrical shock resulting in injury. The TARGA PLC must be installed protected from water and dust. IP67 rated enclosure is optional.</p>
 WARNING	<p>Do not use the electrical controls during operation of the emergency manual override cranks as doing so could cause injury.</p>
 WARNING	<p>ONLY USE THE MANUAL OVERRIDE IN CASE OF TRUE EMERGENCY & POWER FAILURE. The manual override controls on the FORCE 50 are not designed for normal operation and should only be used in the case of extreme emergency and when the remote control feature is not working sufficiently to control the robotic nozzle by means of the electronic controls. In case of use in such an emergency, first disconnect the cables from the motor connections. !!</p>
 WARNING	<p>DISCONNECT POWER PRIOR TO INSTALLATION, MAINTENANCE OR REPAIR. Prior to installation, maintenance or repair be sure to disconnect power and disable flow.</p>

 WARNING	<p>Be sure to use the proper type and size of threads at the robotic nozzle base and also between the robotic nozzle and nozzle (if using a nozzle not supplied by Unifire specifically for use with this robotic nozzle). Use of the wrong type or size of threads will result in an improper connection which can cause leaking and also may cause the robotic nozzle and/or nozzle to dislodge under high pressure, possibly leading to serious injury or death to persons and/or serious damage to property. If you have any doubts as to the exact thread supplied by Unifire, contact Unifire for clarification prior to connecting the robotic nozzle and nozzle.</p>
 WARNING	<p>The FORCE 50 is heavy. EXERCISE caution and SEEK assistance when installing and take care to avoid injury to your back. Seek assistance to help support and twist the robotic nozzle during installation and take care to avoid injury to your back during handling and installation.</p>
 WARNING	<p>BE SURE THAT THE FORCE 50 IS TIGHTLY AND PROPERLY SECURED AT ALL TIMES DURING OPERATION! Serious injury or death can occur if the robotic nozzle is not fully and properly secured and supported. Be sure that the mounting pipe for the FORCE 50 is capable of withstanding a nozzle reaction force of at least eight thousand (8,000) Newtons (800 kgf). The FORCE 50 robotic nozzle should not be used on a portable stand of any kind, as such use can be extremely dangerous and can result in Serious Injury or Death.</p>
 WARNING	<p>NORMALLLY MOUNT THE FORCE Robotic nozzle SO THAT ITS BASE IS PERPENDICULAR TO THE GROUND.</p> <p>If you plan to install the robotic nozzle at an angle or upside-down, please consult UNIFIRE when ordering. Special gear ratio and programming may be required.</p>

INTRODUCTION to this Manual



UNIFIRE FORCE 50 system

This installation and setup manual is intended to provide generic guidance for installation and commissioning of the UNIFIRE FORCE 50 system, including the TARGA Robotic Nozzle PLC and the Ammolite User Interface,

Your system is delivered with user specific functions that can be different than what is described in this manual. Therefore it is important that you reference the order-specific documents provided with the delivery.

This can include custom I/O. terminal socket specification, M12 pin-specifications and special customer specific software.

For further info please see Unifire Robotic Nozzle catalogue
And visit our websites:

www.unifire.com

www.roboticnozzles.com

www.automaticfirefighting.com

and

www.youtube.com/unifireab

Also refer to the system specific documentation

ACRONYM DEFINITIONS

Table 1 defines the acronyms in the user manual.

TABLE 1: ACRONYM DEFINITIONS

Acronym	Definition
AFS	Autonomous fire suppression
AHJ	Authority having jurisdiction
DSP	Digital signal processor
dm	Decimeter
ft	Foot (or Feet)
FACP	Fire alarm control panel
HR	Horizontal range
IR	Infrared
kg	Kilogram
lb (lbs)	Pound(s)
m	Meter
mm	Millimeter
Lpm	Liters per minute
PLC	Programmable logic controller
VDC	Volts of direct current



TABLE OF CONTENTS

WARNINGS

INTRODUCTION TO THIS MANUAL

ACRONYM DEFINITIONS	2-2
---------------------	-----

PLANNING - BEFORE INSTALLATION

About This Manual	3-2
Contacts	3-2
APPROVALS AND STANDARDS	3-2
SAFETY warnings	3-2
Authorized Personnel	3-2
Structural Alterations	3-2
System Limitations	3-4
Building Construction	3-4
Determining a Location	3-4
Water connection	3-4

MECHANICAL INSTALLATION

INSTALLATION GEOMETRY OPTIONS	4-1
Wall, normal orientation	4-1
Wall, inverted orientation	4-2
Ceiling, hanging orientation	4-3
Installation on the wall	4-4
Installation hanging from the ceiling	4-4
Installing The Robotic Nozzle	4-5

FLOW SETTINGS

Nozzle Flow Setting	5-1
Flow chart	5-2
Reach chart	5-3

ELECTRICAL INSTALLATION

Generic system overview	6-1
Connecting the FORCE 50 to the TARGA PLC	6-2
TARGA PLC generic pin-specification	6-3
TARGA Robotic Nozzle PLC TERMINAL SOCKETS	6-4
GENERIC TERMINAL SOCKET SPECIFICATION	6-4

SOFTWARE & CALIBRATION

Calibrating the Robotic Nozzle's operating range	7-1
Ammolite Software Introduction	7-3
Connect your PC or TABLET	7-4

TECHNICAL SPECIFICATIONS SYSTEM COMPONENTS

FORCE 50 QUICK SPECIFICATIONS	8-1
TARGA™ PLC SPECIFICATIONS	8-3
TARGA PLC DIMENSIONS	8-4
X-TARGA™ & X-TARGA-S	8-5
Unifire TARGA PCB	8-7
TARGA PCB	8-7
Unifire Web Server	8-9
CAN Bus Cape	8-11
BLDC Driver Card	8-12
ONE Graphical User Interface	8-13
π™ (P) CAN bus Joystick	8-15
POINTER™ Synchron Joystick	8-16
BLDC Motors	8-17
FORCE 50 SPARE PARTS	8-18
Custom Solutions	8-19

PLANNING - BEFORE INSTALLATION

About This Manual

This manual is a comprehensive guide that contains the information necessary to design, install, operate, and maintain the FORCE 50 Robotic Nozzle system.

Users of this manual are assumed to be competent fire engineers with a basic knowledge of such systems. Users who are not familiar with the equipment should first read the complete manual.

Only certified personal who have undergone UNIFIRE AB training are allowed to install this equipment.

Contacts

Should any part of this manual not be understood, or there are queries concerning the system, contact UNIFIRE AB Technical Support using the following details:

UNIFIRE AB,
Bultgatan 40B
442 40 KUNGÄLV
SWEDEN

Mail: support@unifire.com

www.unifire.com

APPROVALS AND STANDARDS

See Section 2 System Components for approval and listing information for the various components.



SAFETY warnings

A properly designed and installed FORCE 50 Robotic Nozzle should not present any significant health or safety problems. Take basic precautions to avoid accidents. The various aspects of the system's operation must be understood. Observe best practices.

! WARNING

Do not operate this device without a full understanding and comprehension of this manual. Personnel responsible for the FORCE 50 system must be fully trained on the system components.

! WARNING

The installer should pay specific attention to the danger, caution, warning, and notice statements in this manual. Failure to observe safety warnings could cause serious injury, and potentially create liability.

! DANGER

Do not direct the flow stream towards people as it could result in serious personal injury or death.

- Operate and maintain the FORCE 50 Robotic Nozzle system in compliance with this document and with applicable standards, in addition to the standards of any other authorities having jurisdiction (AHJ). Failure to do so impairs the proper operation and integrity of this device.
- The owner must maintain the fire protection unit or system and devices in proper operating conditions.
- Do not, under any circumstance, operate this system outside the water flow or pressure range indicated in this manual.
- The owner must ensure that an uninterrupted supply of water is maintained to the Robotic Nozzle.

Authorized Personnel

The FORCE 50 system shall be installed by authorized personnel certified by UNIFIRE AB. Use components and accessories authorized only by UNIFIRE AB.

Structural Alterations

This installation manual details the suggested installation method. Any structural alteration necessary for installation must comply with local building code requirements.

⚠ DANGER

DO NOT PRESSURIZE THE UNIT until the flange has been properly tightened.

DO NOT PRESSURIZE THE UNIT until the electrical installation and software calibration procedure has been completed

DO NOT PRESSURIZE THE UNIT until the system commissioning has been completed by certified technicians, and a formal release note / approval has been issued.



System Limitations

The system designer shall take into account the building construction or vehicle requirements, location, hydraulic design, coverage area, and number of systems required. If the limitations in these areas are not maintained, the system may not operate correctly.

Building Construction

- **Water demand:** Evaluate the FORCE 50 water system demand as an independent addition to the existing building water supply. Conduct a hydraulic analysis to ensure that it does not affect the building's existing water system design criteria. It is possible to achieve this without significant system supply modifications. However, the system may require increased pump sizes, storage tank capacity, and pipe sizes.

Determining a Location

Contact your local technical support team for assistance in determining the optimal location of the system components.

Water connection

The FORCE 50 is normally delivered with a DN50/PN16 stainless steel flange.

Options include 2" male BSP, JIS and ANSI flanges, and customer specific brackets.

Please discuss the connection with your sales representative and please specify the requested connection when ordering.



MECHANICAL INSTALLATION

INSTALLATION GEOMETRY OPTIONS

The FORCE 50 Robotic Nozzle can be installed geometrically in three different orientations:

The Robotic Nozzle can be installed with

Wall, Normal orientation

Wall, Inverted orientation

Ceiling, hanging orientation

Wall, normal orientation

Use when the water supply comes from below

Use when the Robotic Nozzle is installed on a wall, allowing a maximum of 180° horizontal and +/- 90° vertical movement. The TARGA PLC must be installed next to the Robotic Nozzle

CAUTION!

This orientation is suitable for manual operation with Joystick. This is standard geometry.

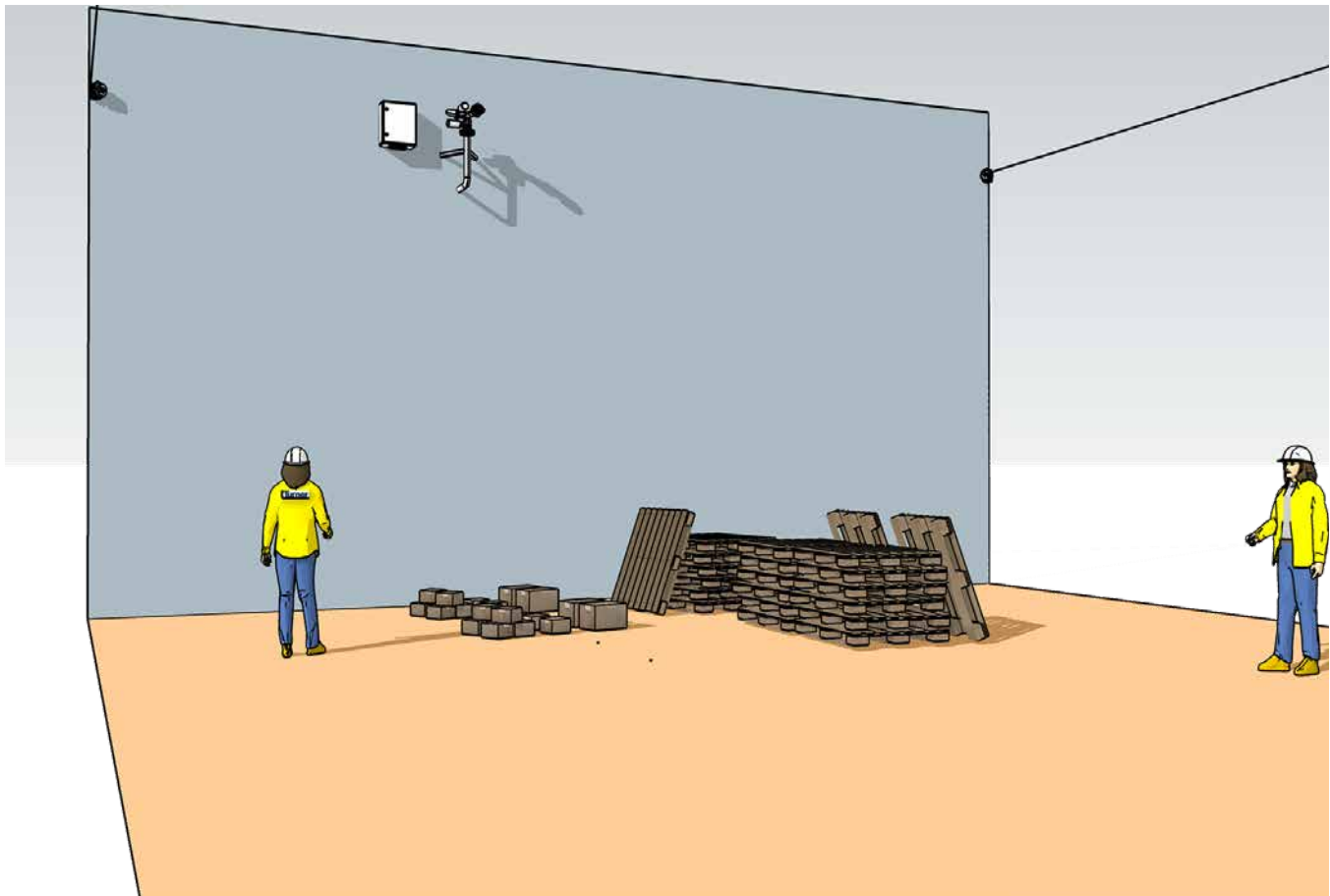
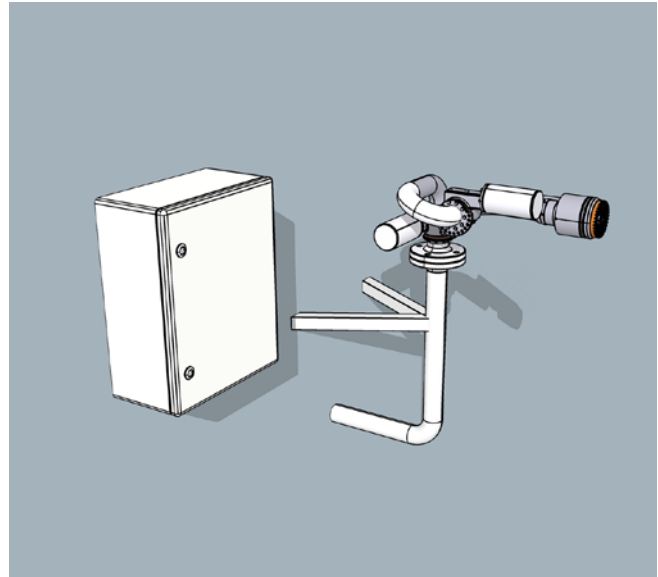

Wall, inverted orientation

Use when the water supply comes from above.

Use when the Robotic Nozzle is installed on a wall, allowing a maximum of 180° horizontal and +/- 90° vertical movement

The TARGA PLC must be installed next to the Robotic Nozzle.

This geometry is suitable for manual operation with Joystick

CAUTION!

For inverted orientation the geometry of the FORCE 50 must be inverted, hence please advise the required orientation / geometry when ordering.

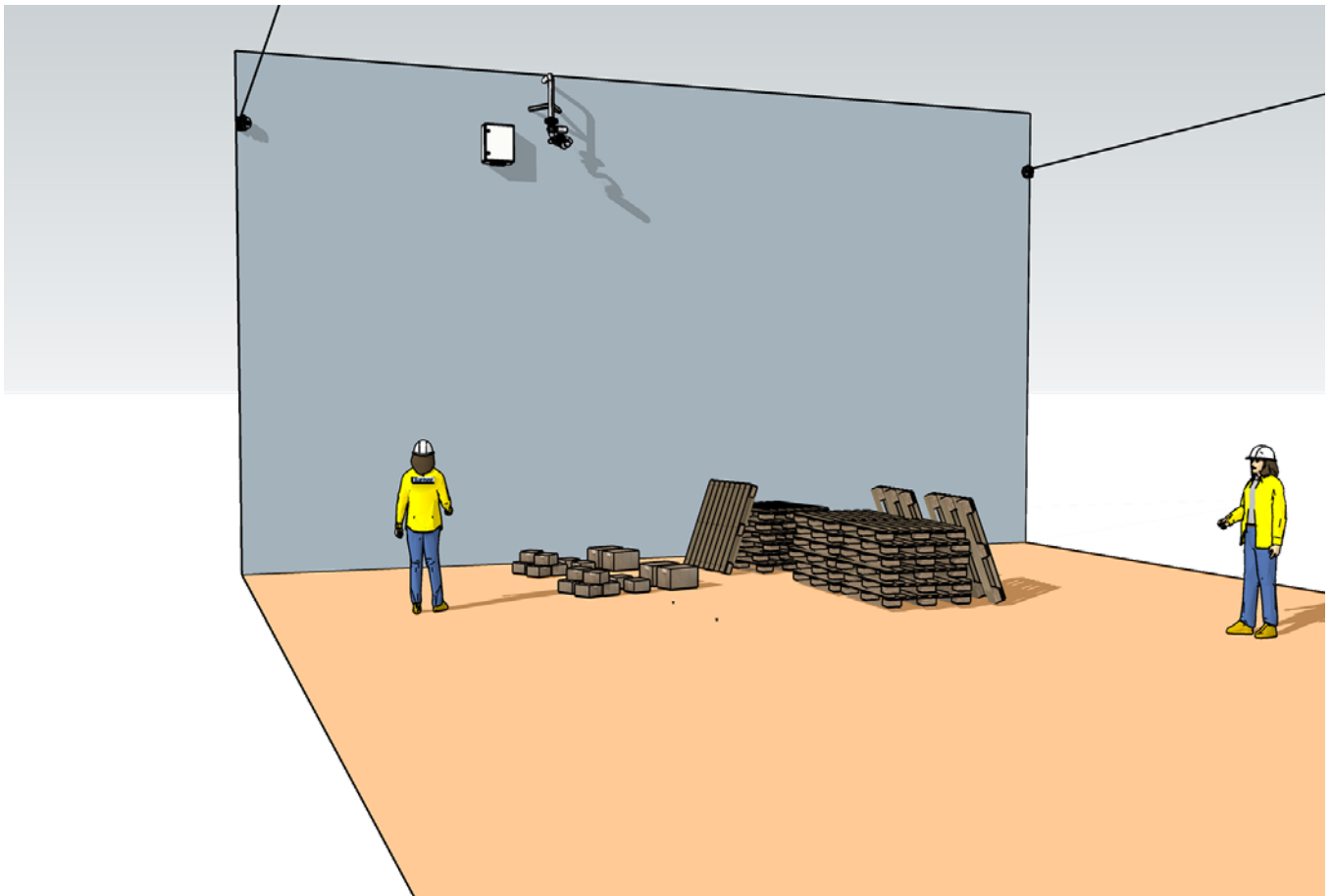
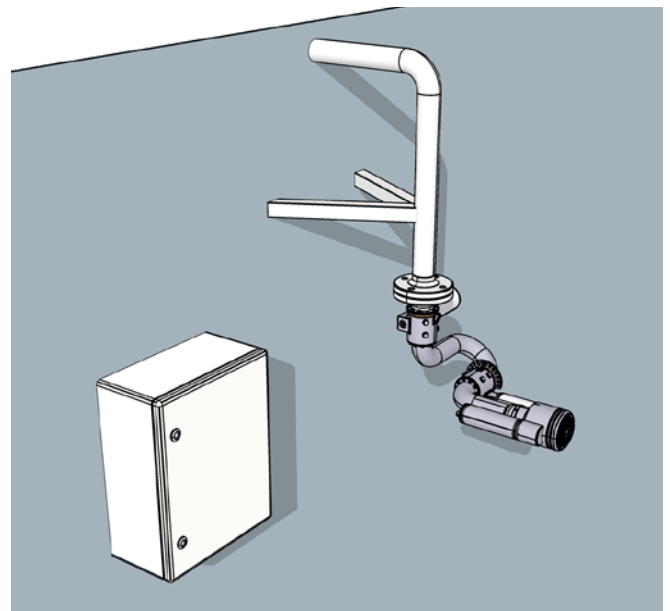

**MECHANICAL INSTALLATION
FORCE 50**

REV. 2.2 2021-02-04

4-3

Ceiling, hanging orientation

Installing the Robotic Nozzle hanging from the ceiling usually provide the best reach and coverage.

The Robotic Nozzle can be installed in the center of the area covered by the detector, thus allowing a full 360° coverage of up to 70 m Ø (35 m reach in all directions)

This is usually the preferred orientation for autonomous systems - when the FORCE 50 is controlled from detectors or a Thermal imaging system.

This orientation is not suited for manual operation with a Joystick or the ONE App.

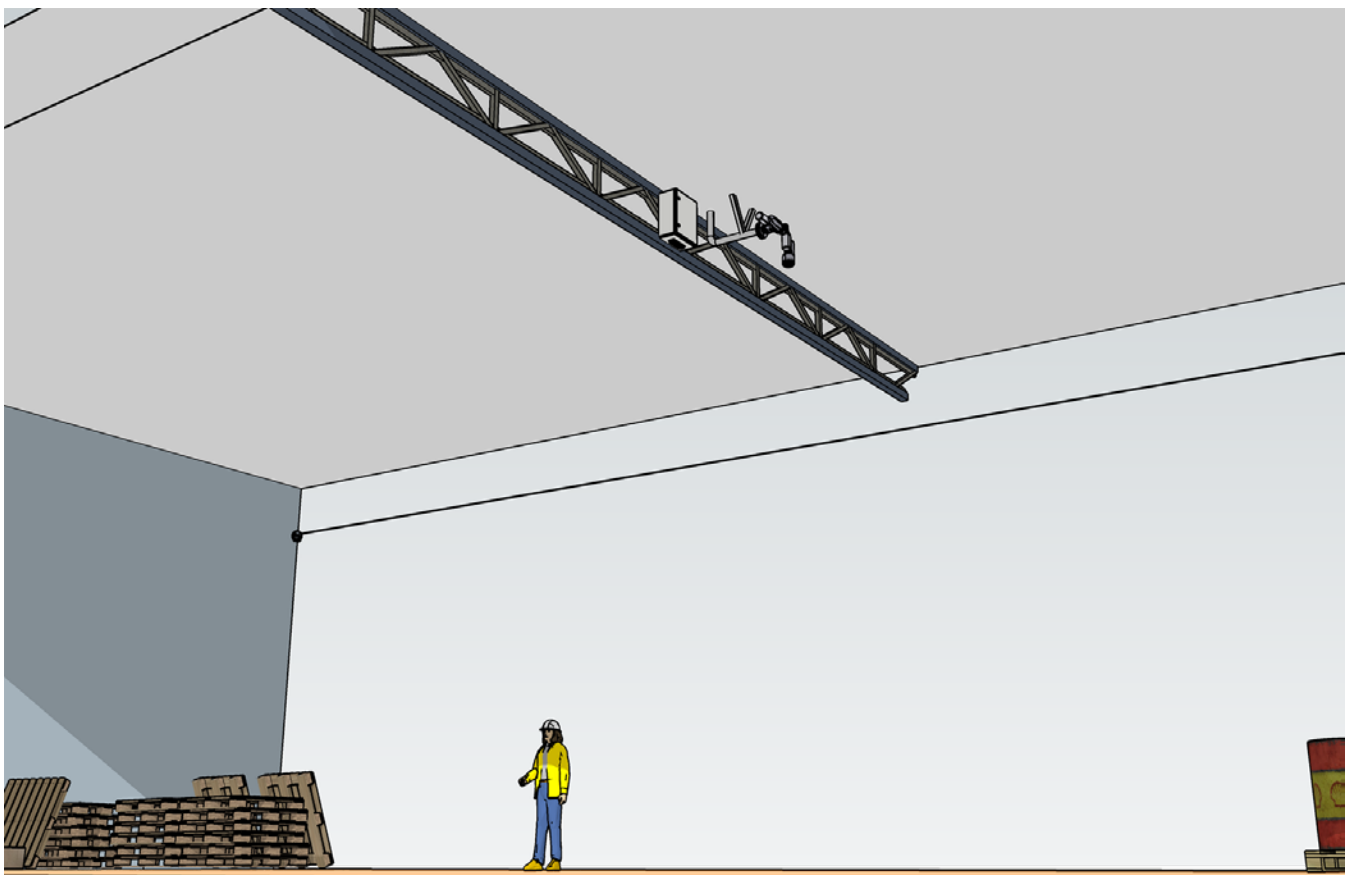
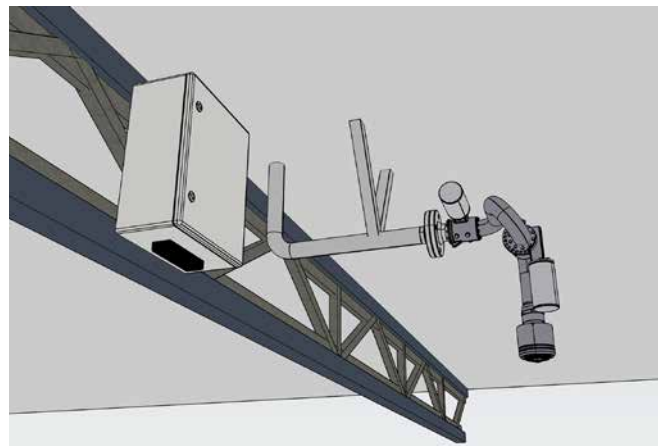

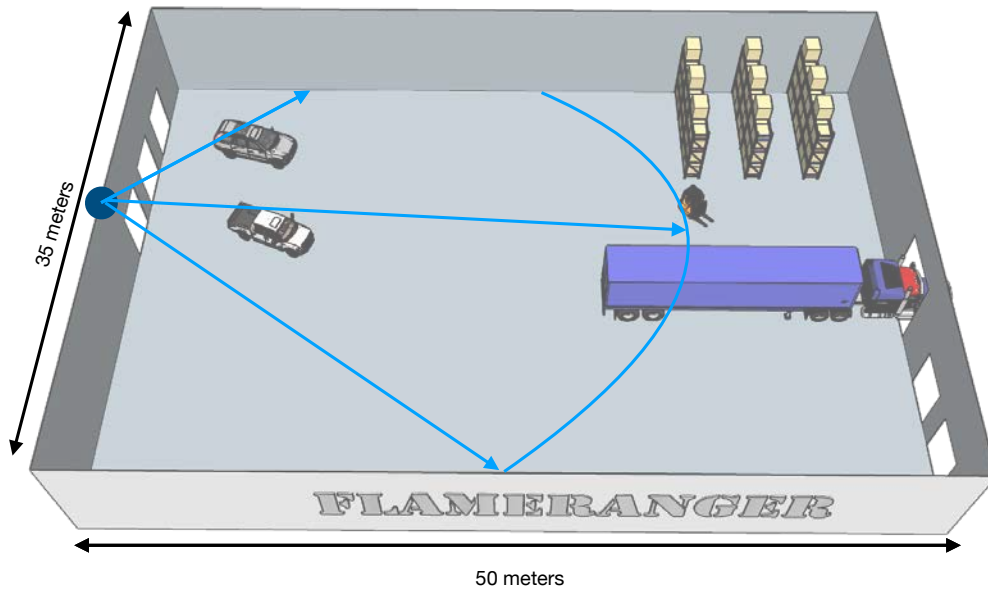

Installation on the wall

Usually provides easier access, thus it makes installation easier. The cover is limited to only 180° horizontal reach. An area of up to 40 m radius is protected. Installing on a wall provides a geometry suited for manual Joystick control.

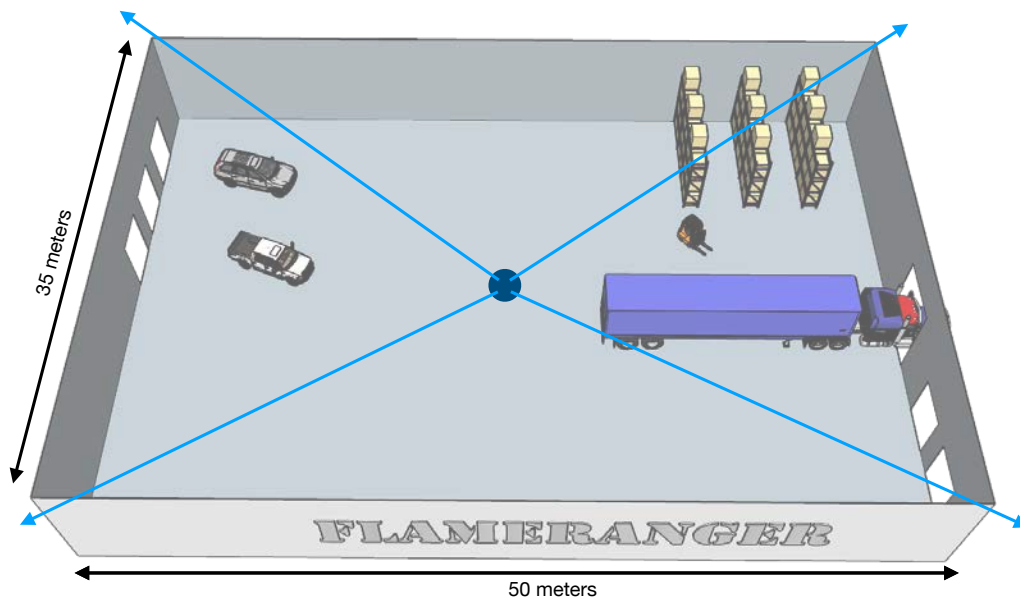

Installation hanging from the ceiling

Is recommended for fully automatic systems. It usually will provide better reach, the stream is less obstructed by objects on the floor. Up to 40 m reach provide a full 80 meter Ø cover. It is however difficult to control with a manual Joystick, because the geometry is rotated 90°, with the Nozzle facing straight down in default position.

**MECHANICAL INSTALLATION
FORCE 50**

REV. 2.2 2021-02-04
4-5

Installing The Robotic Nozzle

By now we assume you have decided if the Robotic Nozzle is to be installed on the wall, or hanging from the ceiling.

The FORCE 50 Robotic Nozzle is fitted with a DN50/PN16 flange (or similar size 2" ANSI flange or JIS flange).

! WARNING

The maximum reaction force at 2000 lit/min and 10 bar is 1400 N. The mounting pipe and bracket must withstand minimum 8 000 N of Force, to provide a safe and stable base.

The flange itself provides the required support to hold the FORCE 50. Additional support and brackets must be applied to the feeding pipe to keep it stable under operation. This is especially important during fully automatic operation. Use suitable M16 bolts and a flat seal to install the flange.

! CAUTION

Clearance!!

Take special precaution to ensure the Robotic Nozzle can move and rotate freely +/- 90° in all directions

Make sure there are no obstructions with 600 mm from the centre of rotation



The FORCE 50 weighs 19 Kg incl flange and nozzle

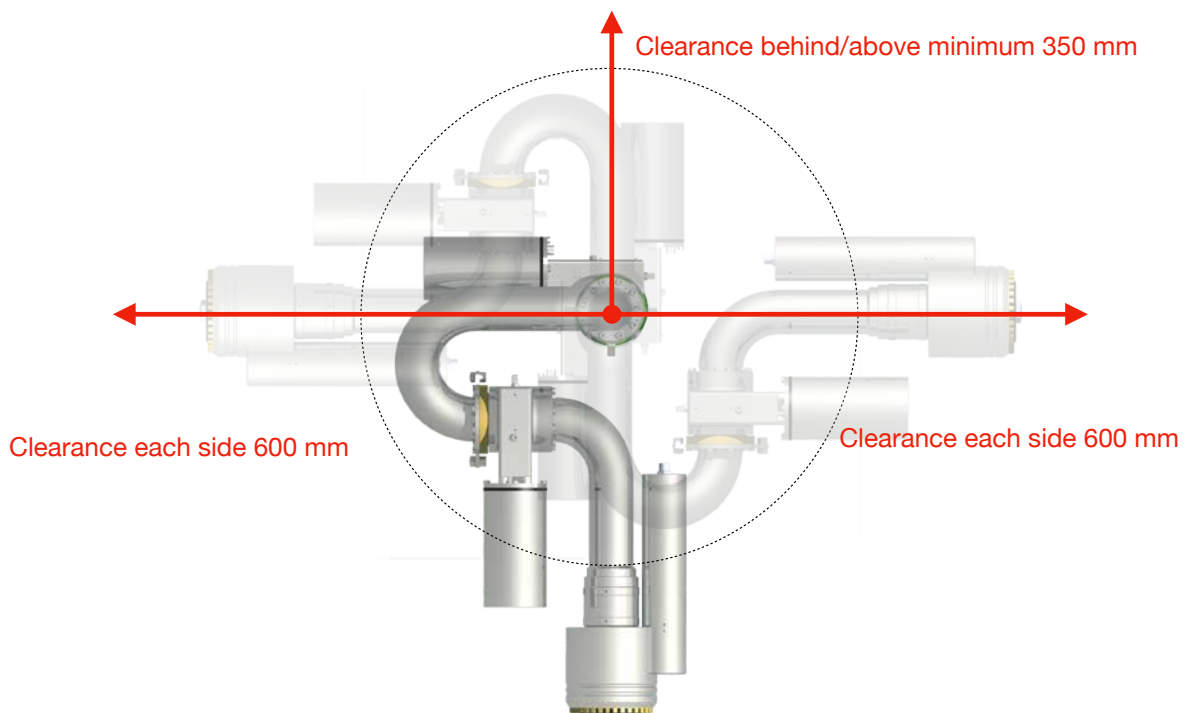

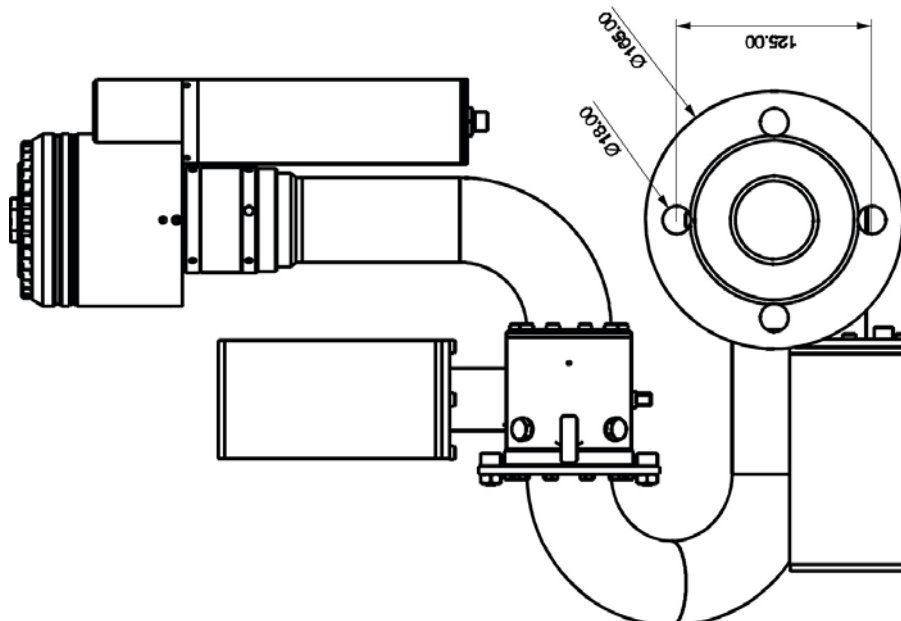
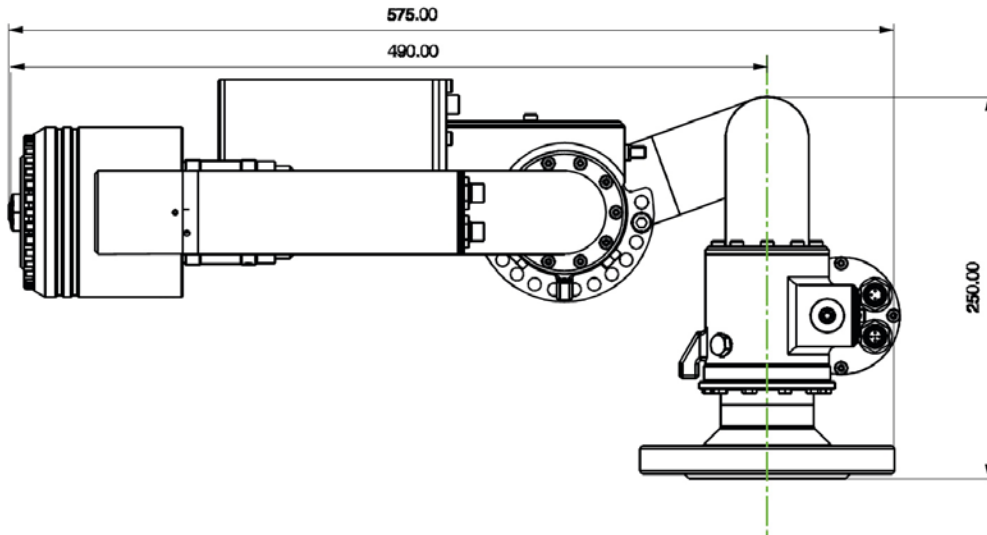
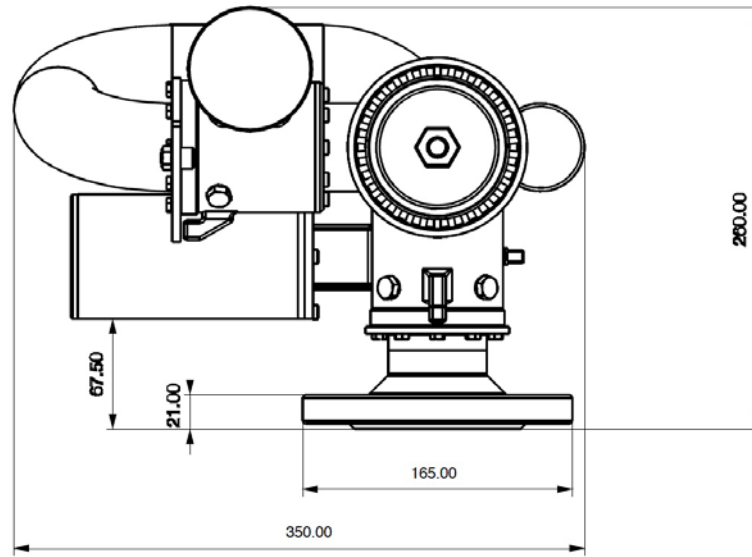

FLOW SETTINGS

Nozzle Flow Setting

The Nozzle flow can easily be selected by fitting the appropriate flow shim.

The shim is custom manufactured (3D printed) to fit each order.

Please specify your required flow at your system pressure when ordering.

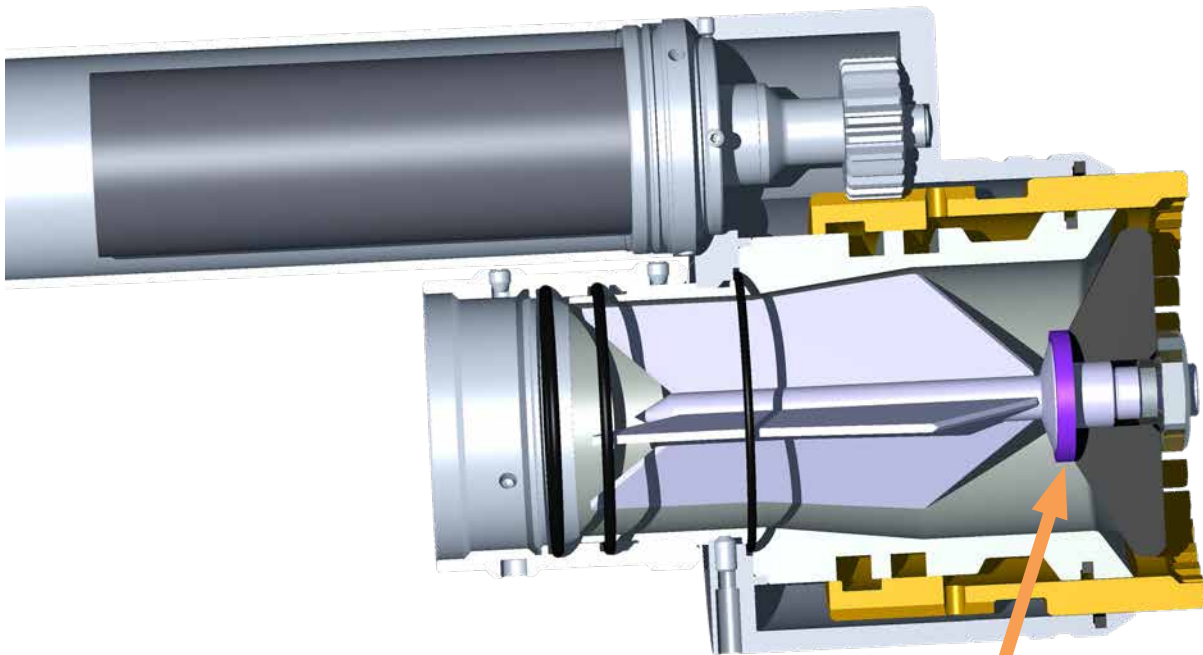

FLOW SHIMS

Flow shims are 3D printed specifically to order.

Typically in dimension (thickness) 0,8-6,2 mm

See flow and reach charts on the following pages



Flow chart

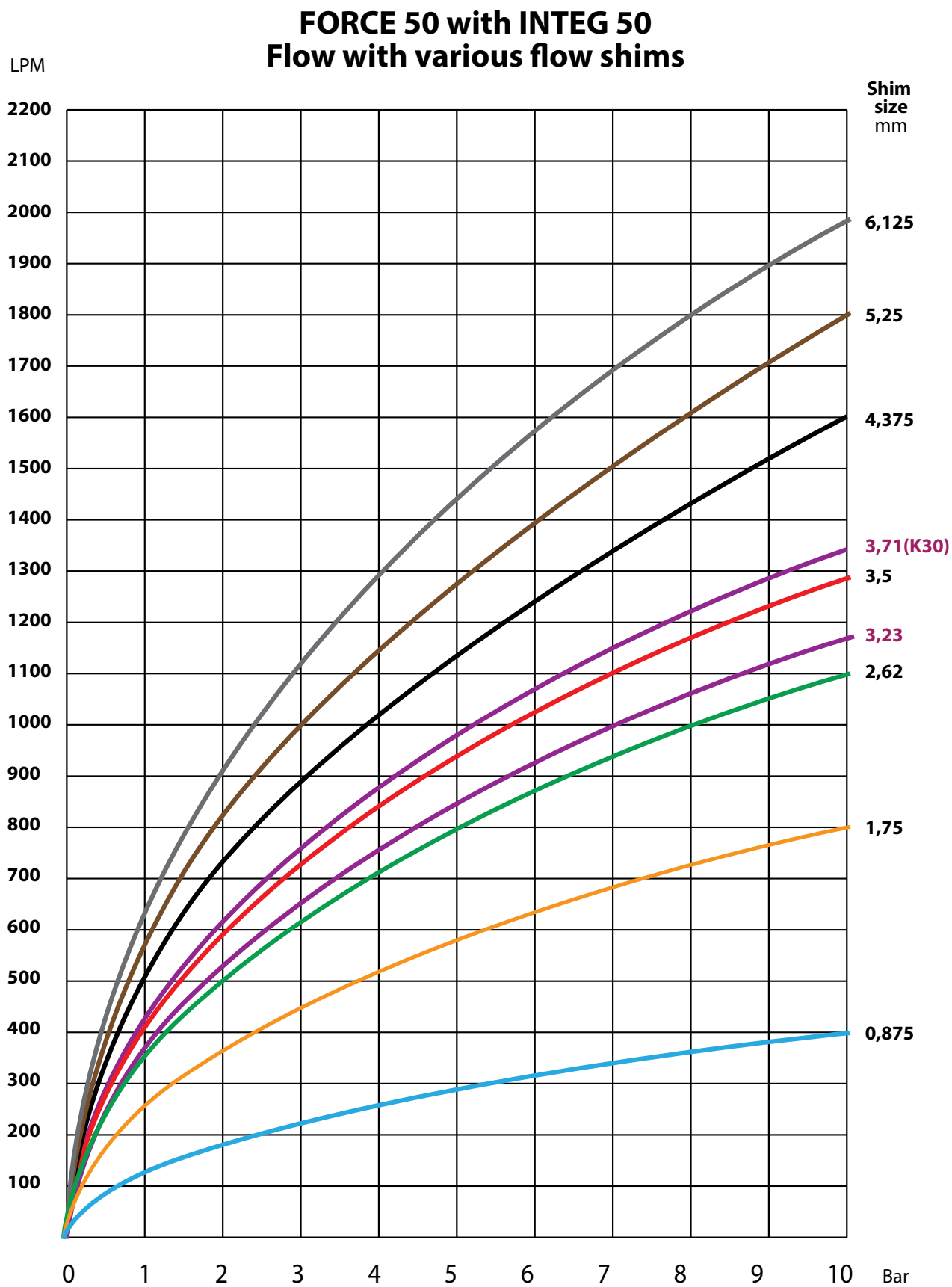

Reach chart

FORCE 50 with INTEG 50 Max reach at 35° discharge angle

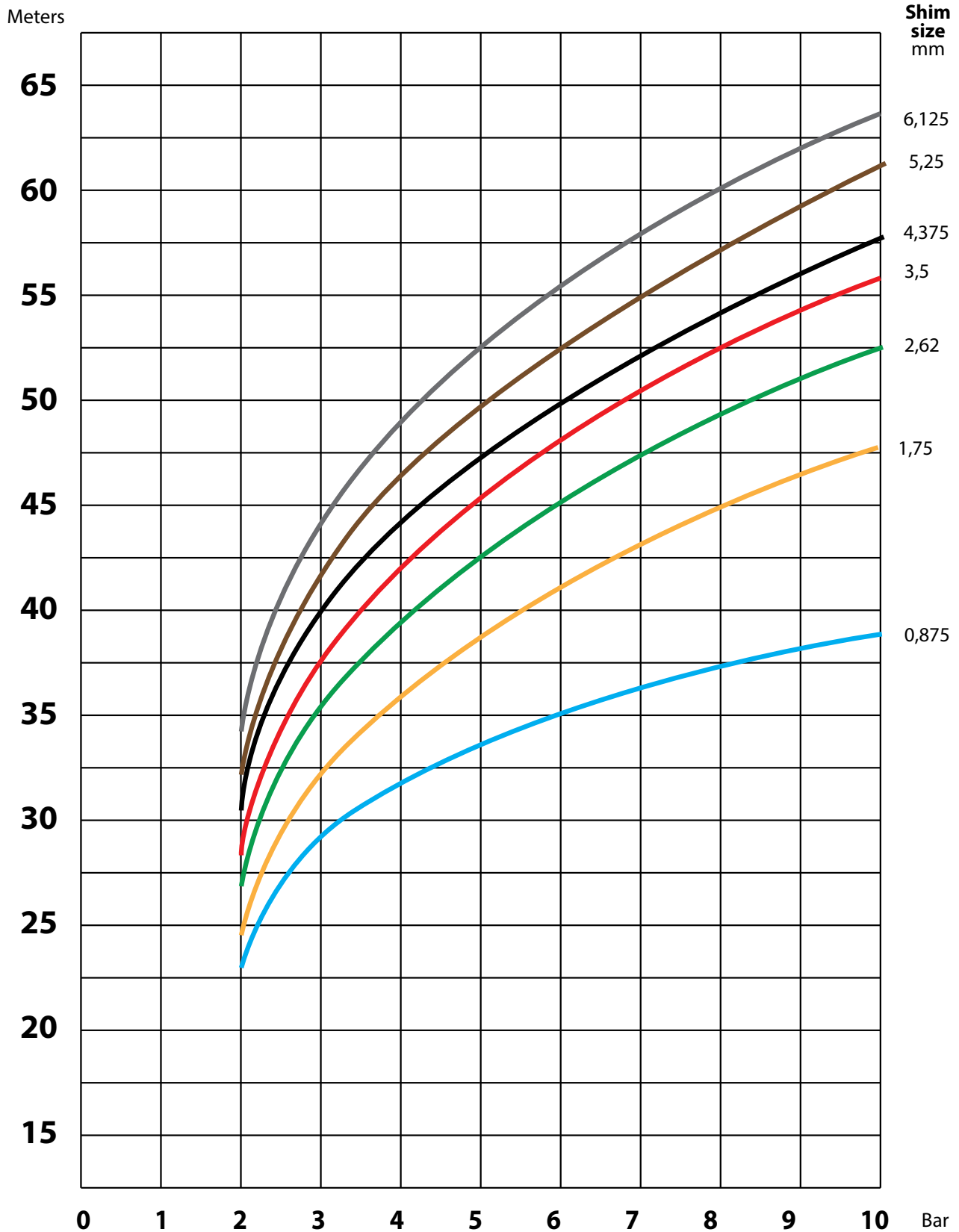

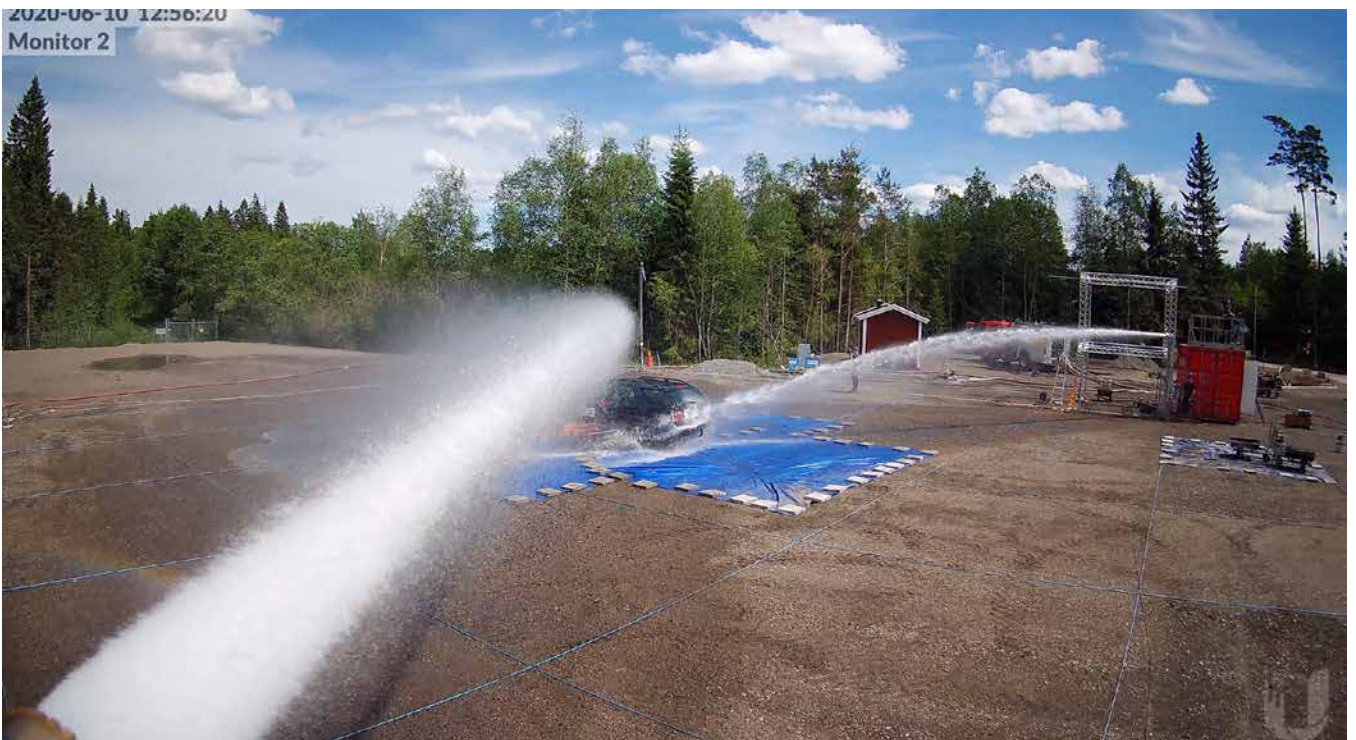

ELECTRICAL INSTALLATION

Generic system overview

The TARGA Robotic Nozzle PLC is a highly capable programmable PLC. With support for up to 6 x BLDC drivers

Communication Protocols: 2 x CAN 2.0 29-bit header (UniCAN) 125,250,500 kB/s, RS232, RS485 (Modbus, DMX, etc.)

Physical Layer Protocols: USB, Ethernet (TCP/IP, web socket), others available per customer requirements

6 BLDC Motor Driver Card Slots (optional: slots for DO or DI/AI expansion cards)

Inputs: 4 digital inputs (NPN) + 2 per installed motor driver card, 6 analogue inputs (4-20 mA or 0-5V), expandable & customizable to customer requirements

Outputs: 8 digital outputs, of which 4 can be set to PWM.

Below is a generic example of what a system can look like.

A DHCP Router is required to set up the system with the Ammolite GUI. This will also allow for the ONE App to be activated

Over the web interface the systems can be remote controlled and remotely configured and monitored. From anywhere in the world.

A cabled Canbus Joystick can be connected for local control.

An industrial radio remote control (Hetricon ERGO-S) can also be locally connected.

Digital and analogue outputs are generic and can be used to operate valves, and send or receive status signals.

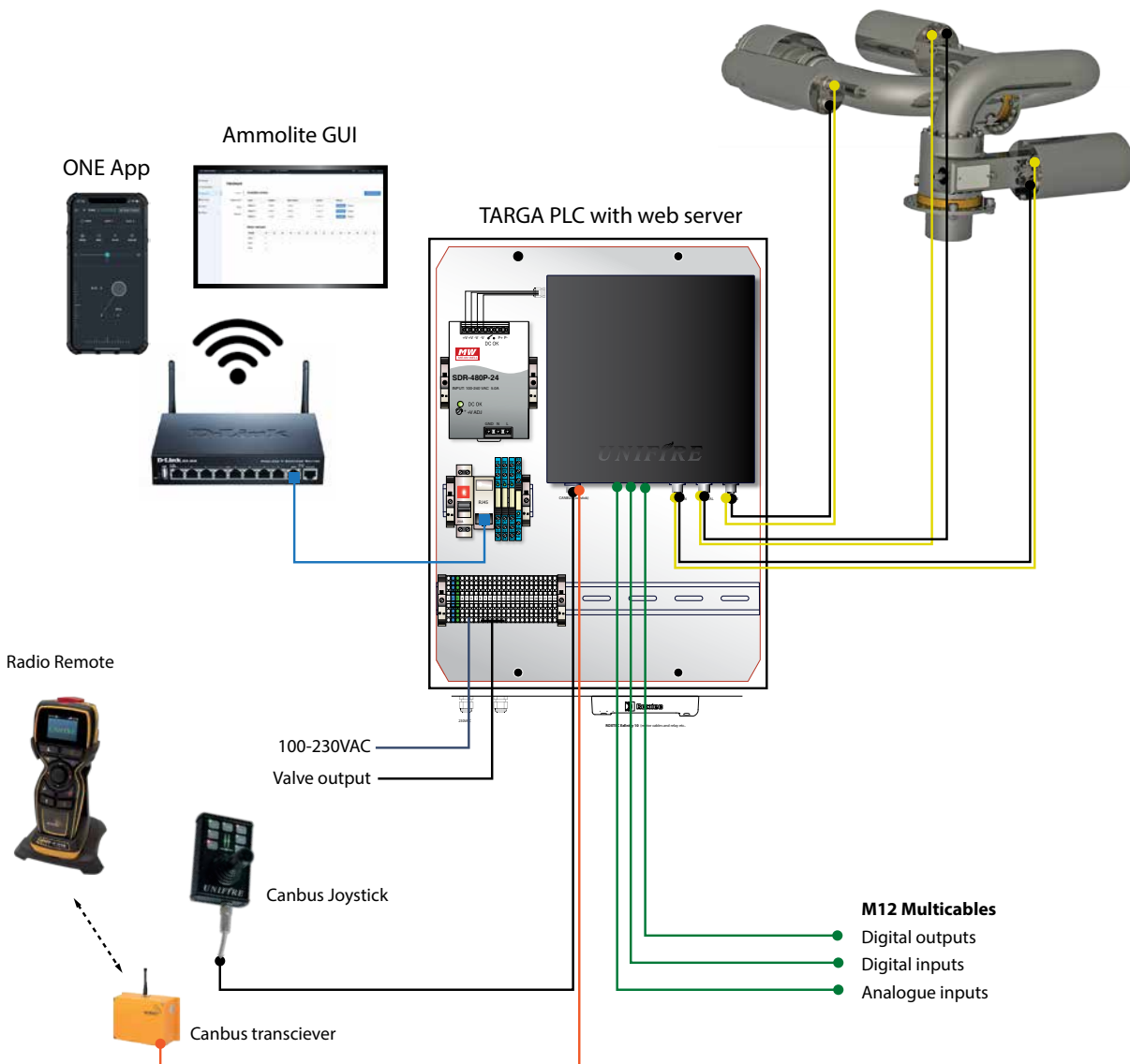

Connecting the FORCE 50 to the TARGA PLC

The FORCE 50 system is fitted with M12 multi connector.
The standard system is delivered with 5-meter M12 cables

Connect the 6 x 5 meter M12 cables from the PLC to the Robotic Nozzle

From left to right: Rotation, Vertical, Nozzle

Yellow A-coded connectors are for the BLDC Motor Sensors .

Black B-coded connectors are for the BLDC Motor Phases.

The key-coding makes it impossible to accidentally cross the cables.

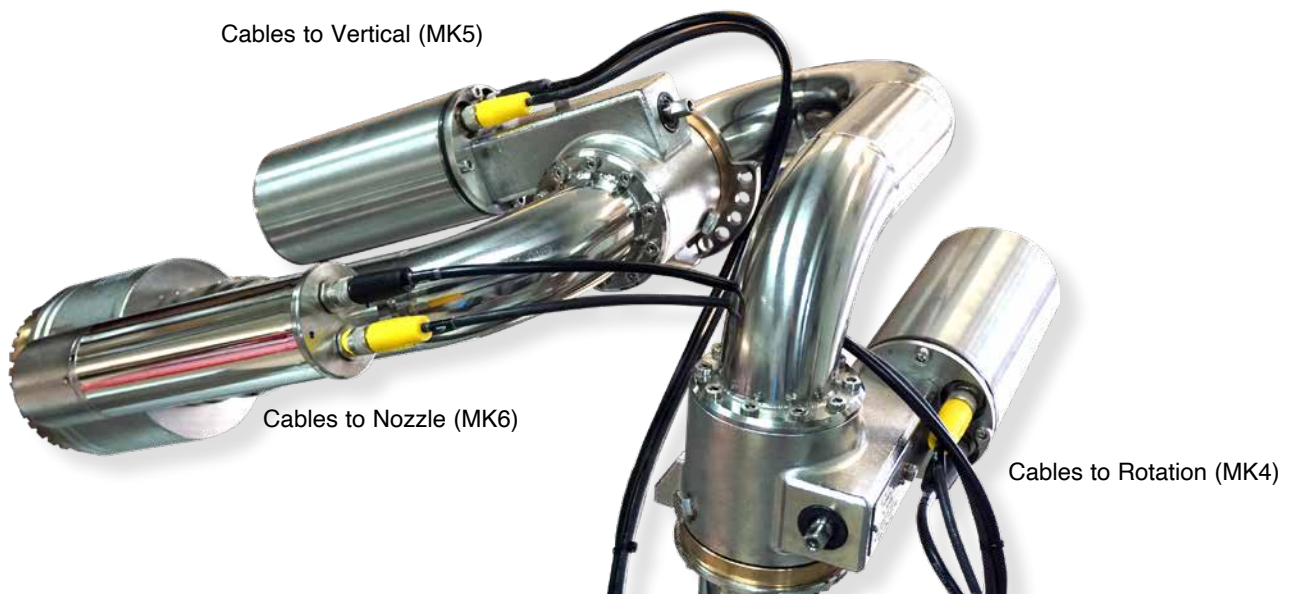

TARGA PLC generic pin-specification

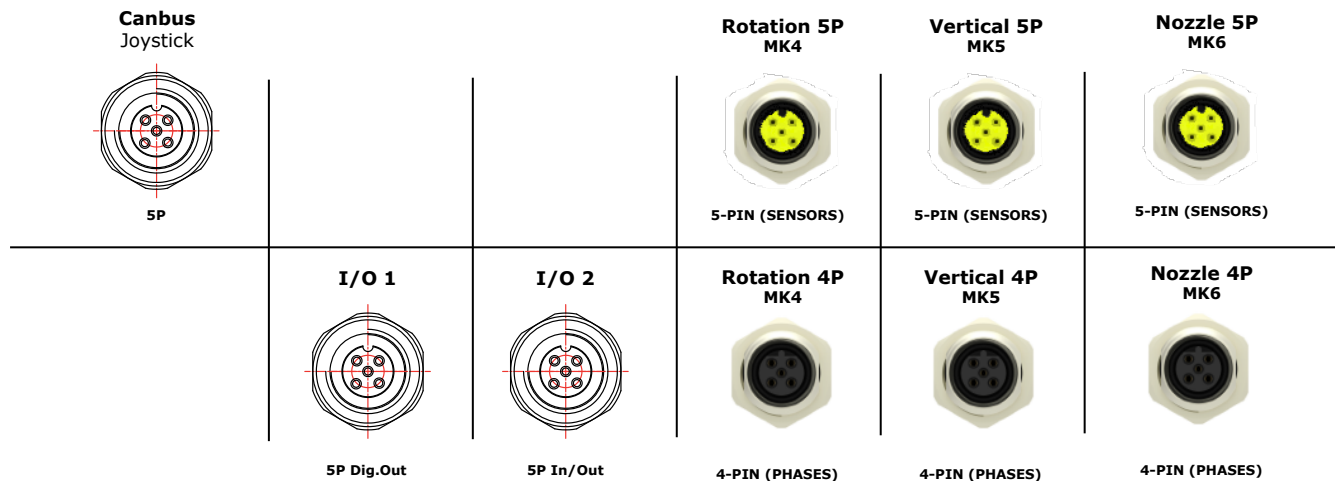

5-PIN A-coded (sensors)

- 1 - BROWN
- 2 - WHITE
- 3 - BLUE
- 4 - BLACK
- 5 - GREY

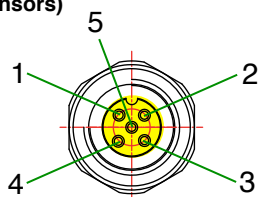

4-PIN B-coded (phases)

- 1 - BROWN
- 2 - n/a
- 3 - BLUE
- 4 - BLACK
- 5 - n/a

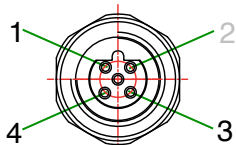

Joystick 5P Canbus		BLDC sensors M12 A-coded 5-pin Rotation / Vertical / Nozzle	
P1	Shield	P1	GND
P2	24 VDC	P2	5 VDC
P3	GND	P3	HALL 3
P4	CAN H	P4	HALL 2
P5	CAN L	P5	HALL 1

M12 5, 8 or 12-pin Dig In/Out		BLDC phases M12 B-coded 4-pin Rotation / Vertical / Nozzle	
P1	generic	P1	PHASE 1
P2	generic	P2	not connected
P3	generic	P3	PHASE 2
P4	generic	P4	PHASE 3
P5	generic	P5	not connected

TARGA Robotic Nozzle PLC TERMINAL SOCKETS



RITTAL 1045500



GENERIC TERMINAL SOCKET SPECIFICATION

Terminal	Function	Internal connection	External connection	Function	Cable mark	Cable dim.	Color marking
1	L1	L (PSU)	AC Power	Power	1	1,5 mm ²	Brown
2	N	N (PSU)	AC Power	Power	2	1,5 mm ²	Blue
3	GND	GND (PSU)	AC Power	Power	3	1,5 mm ²	G/Y
4	CAN 1 H	Main board	Joystick connection box (Optional)	CAN		0,3 mm ²	Black
5	CAN 1 L	Main board	Joystick connection box (Optional)	CAN		0,3 mm ²	Grey / G/Y
6	GND	Main board	Joystick connection box (Optional)	CAN		0,3 mm ²	Blue
7	VCC	Main board	Joystick connection box (Optional)	CAN		0,3 mm ²	White
8	NC	Relay 1	Valve Signal	Relay	8	0,5 mm ²	
9	COM	Relay 1	Valve Signal	Relay	9	0,5 mm ²	
10	NO	Relay 1	Valve Signal	Relay	10	0,5 mm ²	
11	NC	Relay 2	Valve Signal	Relay	11	0,5 mm ²	
12	COM	Relay 2	Valve Signal	Relay	12	0,5 mm ²	
13	NO	Relay 2	Valve Signal	Relay	13	0,5 mm ²	
14	NC	Relay 3	Spare	Relay	14	0,5 mm ²	
15	COM	Relay 3	Spare	Relay	15	0,5 mm ²	
16	NO	Relay 3	Spare	Relay	16	0,5 mm ²	
17	NC	Relay 4	Spare	Relay	17	0,5 mm ²	
18	COM	Relay 4	Spare	Relay	18	0,5 mm ²	
19	NO	Relay 4	Spare	Relay	19	0,5 mm ²	

SOFTWARE & CALIBRATION

Calibrating the Robotic Nozzle's operating range

Before attempting to operate, the Robotic Nozzle must be calibrated = given an operating range.

The calibration is performed through the Ammolite user interface as described in this section.

Calibrate operating range by following step 1-22 as set out on the following pages.

Wall mounted Nozzle

For wall mounted system, the origo/default position is normally that the Nozzle is pointing center (with $\pm 90^\circ$ horizontal movement), and level to ground (with $\pm 90^\circ$ vertical movement)

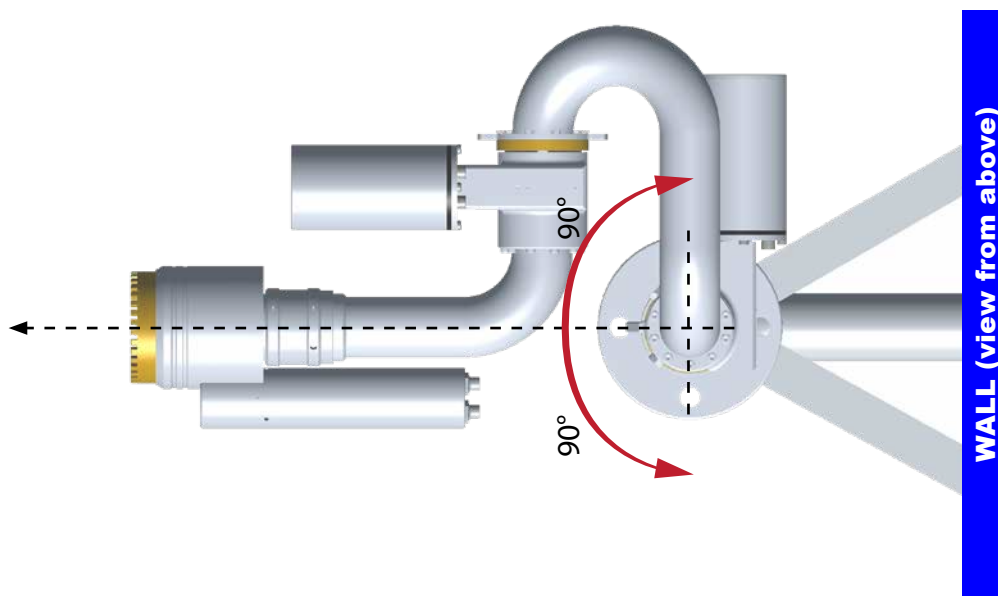
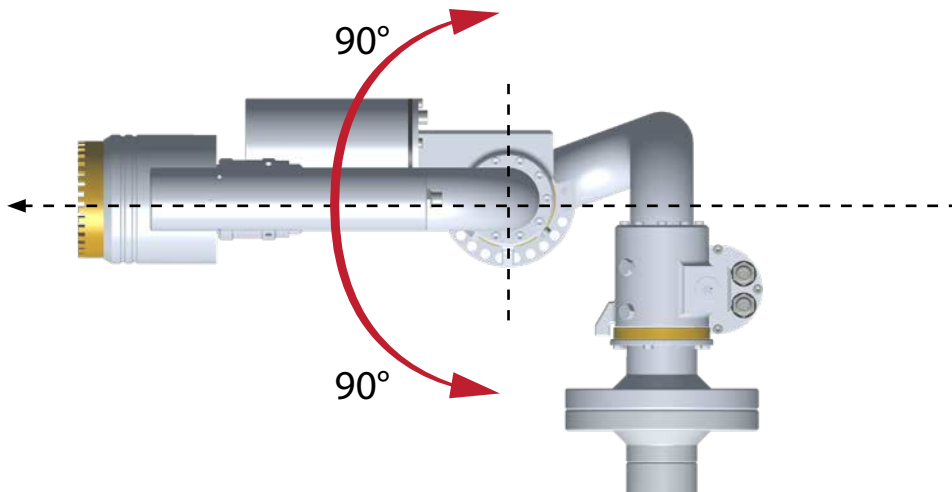

Max vertical range is $\pm 90^\circ$ if there are no mechanical obstructions.

Max horizontal range is 360° if there are no mechanical obstructions.

Ceiling mounted Nozzle

For ceiling mounted system, the origo/default position is normally that the Nozzle is pointing **straight down on both axes**.

Please follow the step-by-step instructions on the following pages to calibrate the operating range.

CEILING (view from the side)

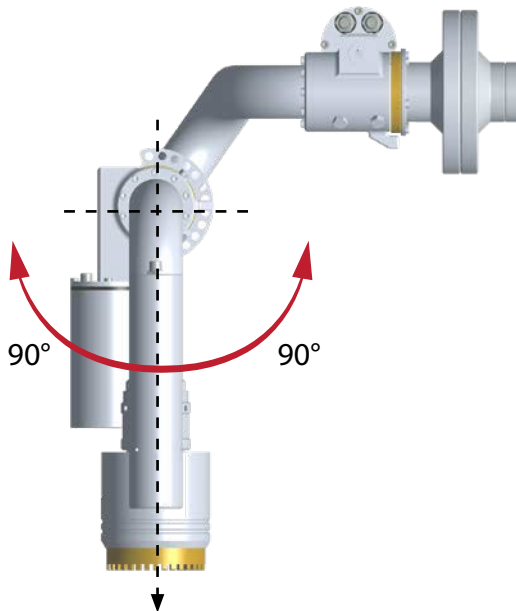

CEILING (view from the side)

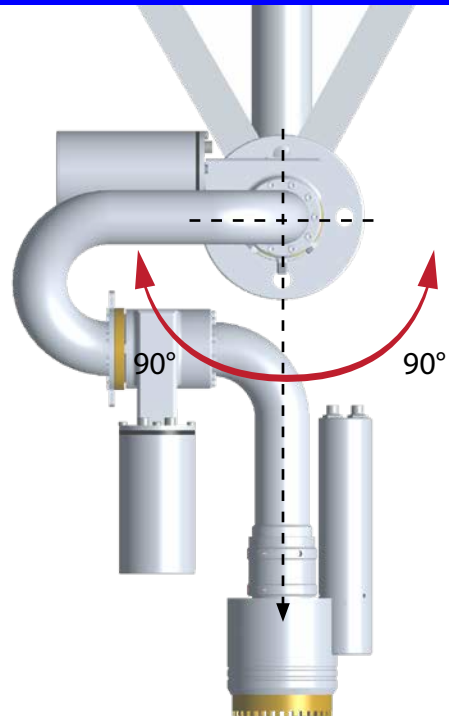

Ammolite Software Introduction

Unifire FORCE 50 set up is achieved through our web browser-based graphical user interface (GUI) called “Ammolite™”. The Unifire TARGA ROBOTIC NOZZLE PLC connects to a standard TCP/IP based network. The built-in web server has been set up to be assigned an IP address by an external DHCP server. This can be a local router or a dedicated server in a larger network, administered by your IT department or similar.

To connect to the web-server, open a browser **Chrome** or **Firefox** and enter the IP address followed by :81 (ex: <http://192.168.0.45:81>, replace 192.168.0.45 with the actual IP).

Enter the username and password provided for your system to access the setup environment.

It is required that you make a note in the service log at login.



Connect your PC or TABLET

Connect your PC or Tablet by WiFi or cable to the same network as the TARGA PLC.

Find IP address of the TARGA PLC as automatically assigned by the DHCP server

Enter the IP address, followed by :81 in the browser window.

For example: <http://192.186.0.45:81>

Then follow instructions to calibrate on the following pages.

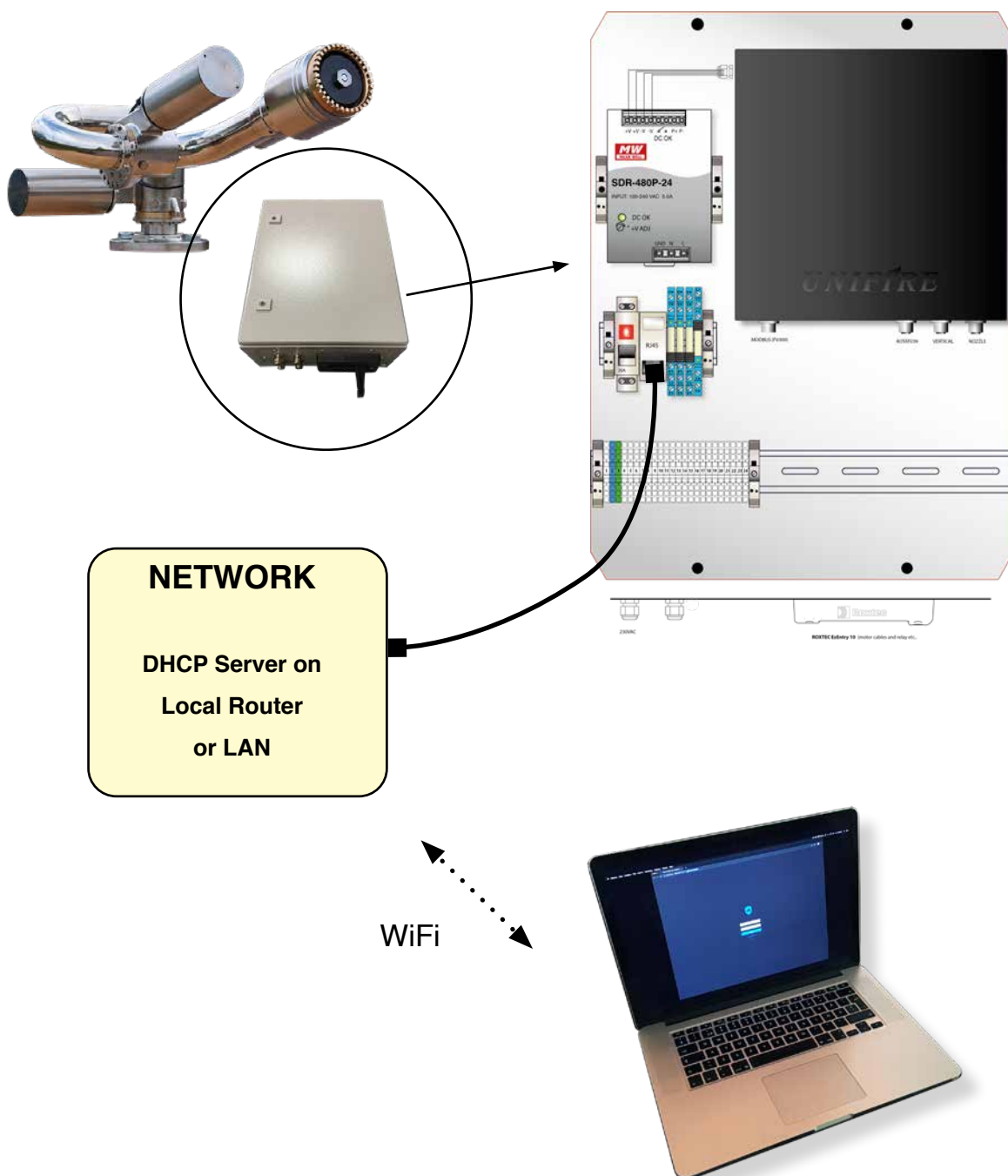

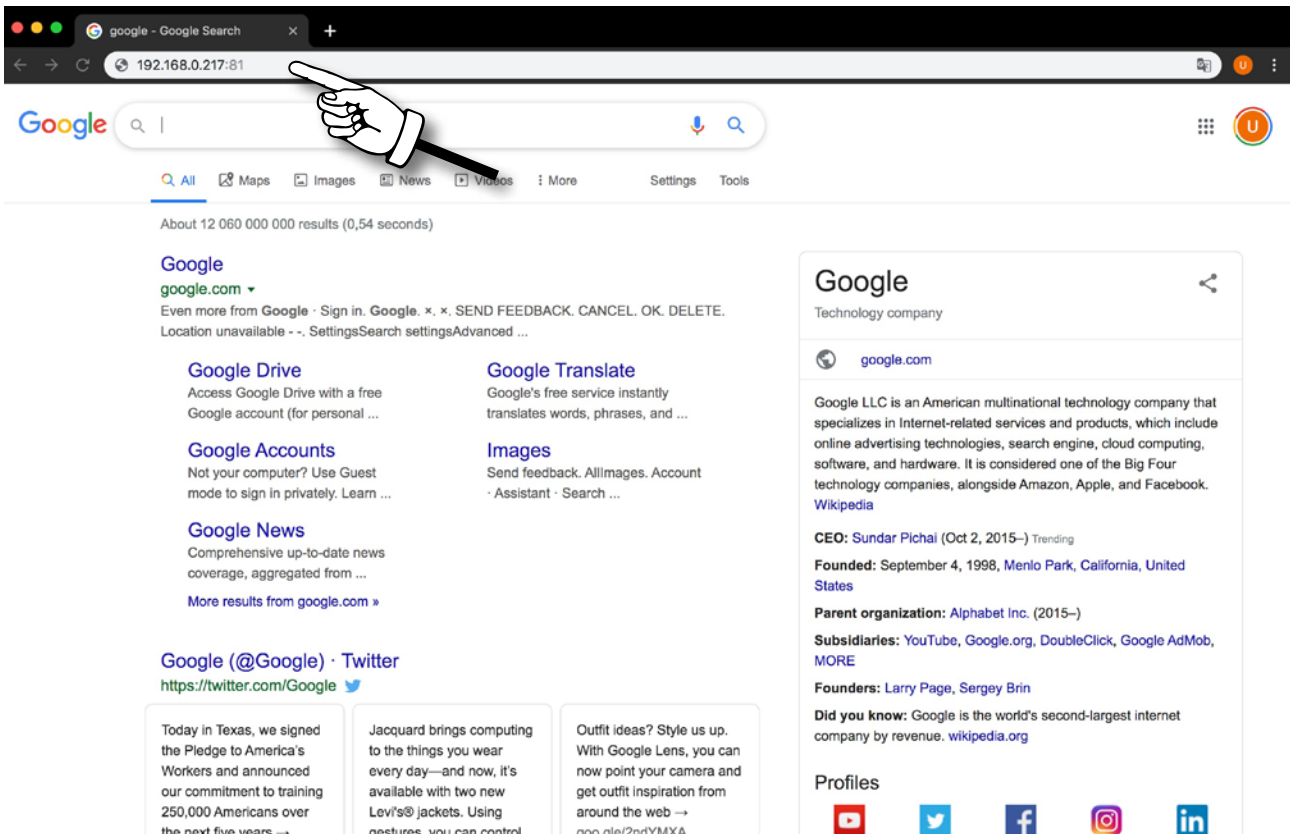

1) Open your web-browser (Safari, Chrome, Firefox or other...)

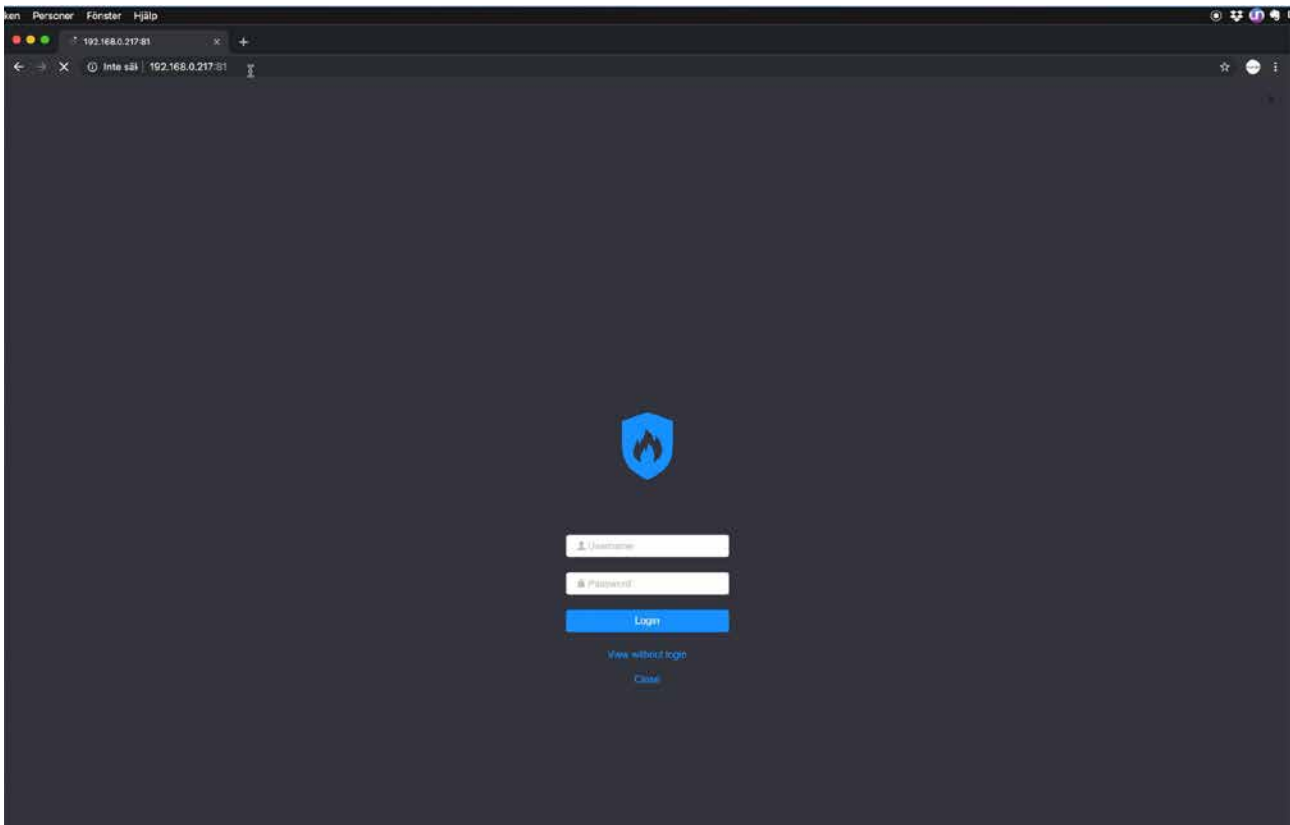

2) Enter the IP Address of the TARGA PLC, followed by :81 (for example http://192.168.0.217:81). Push Enter.

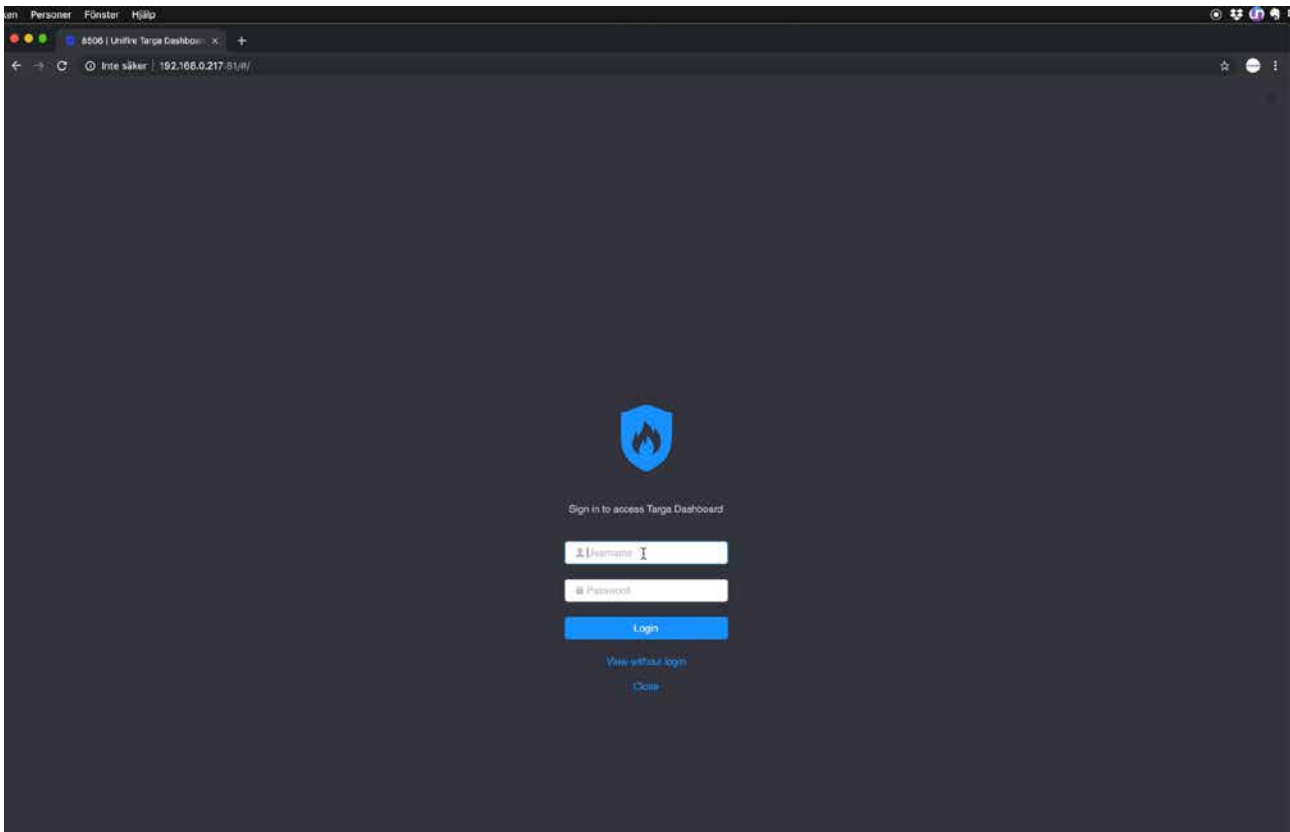

3) Enter the username and password provided with your delivery.

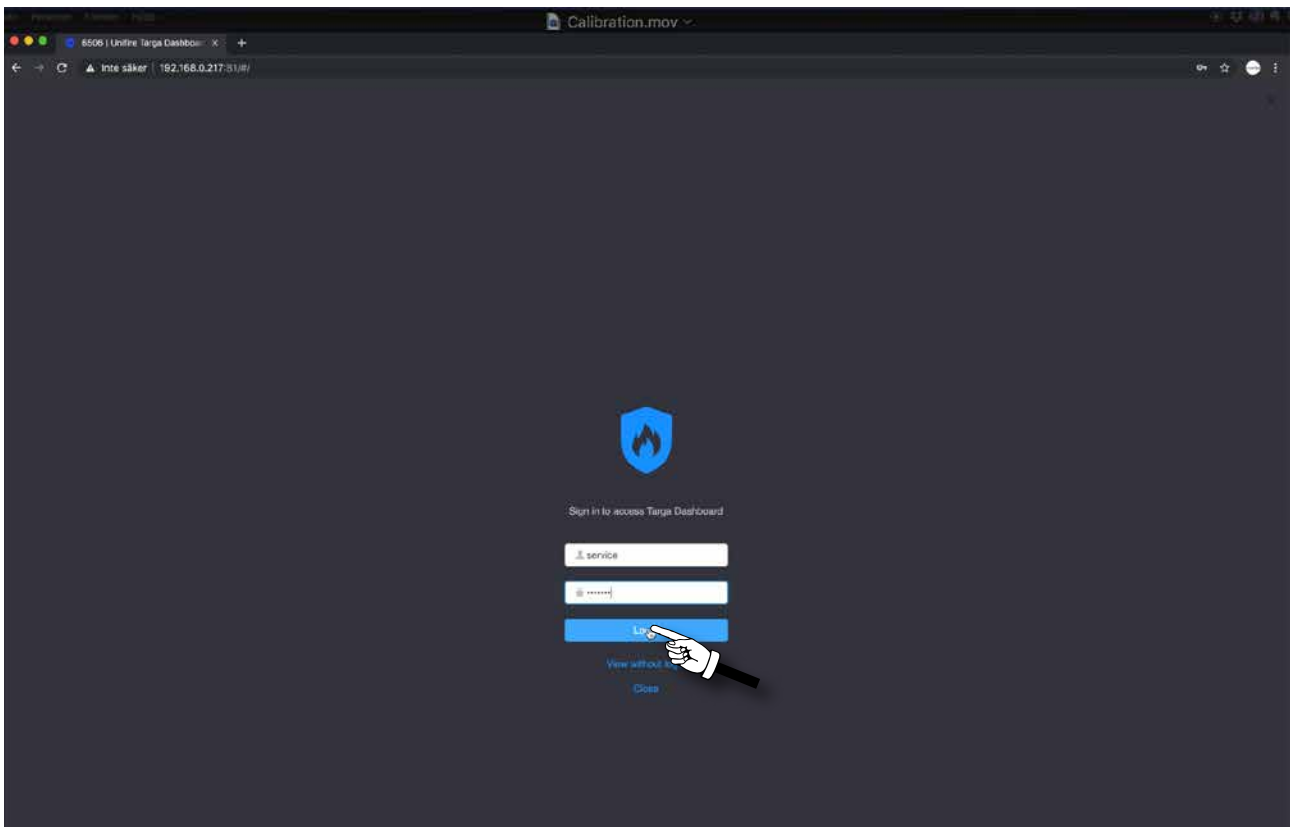

4) In this example it is “service” and “service”. Click Login.

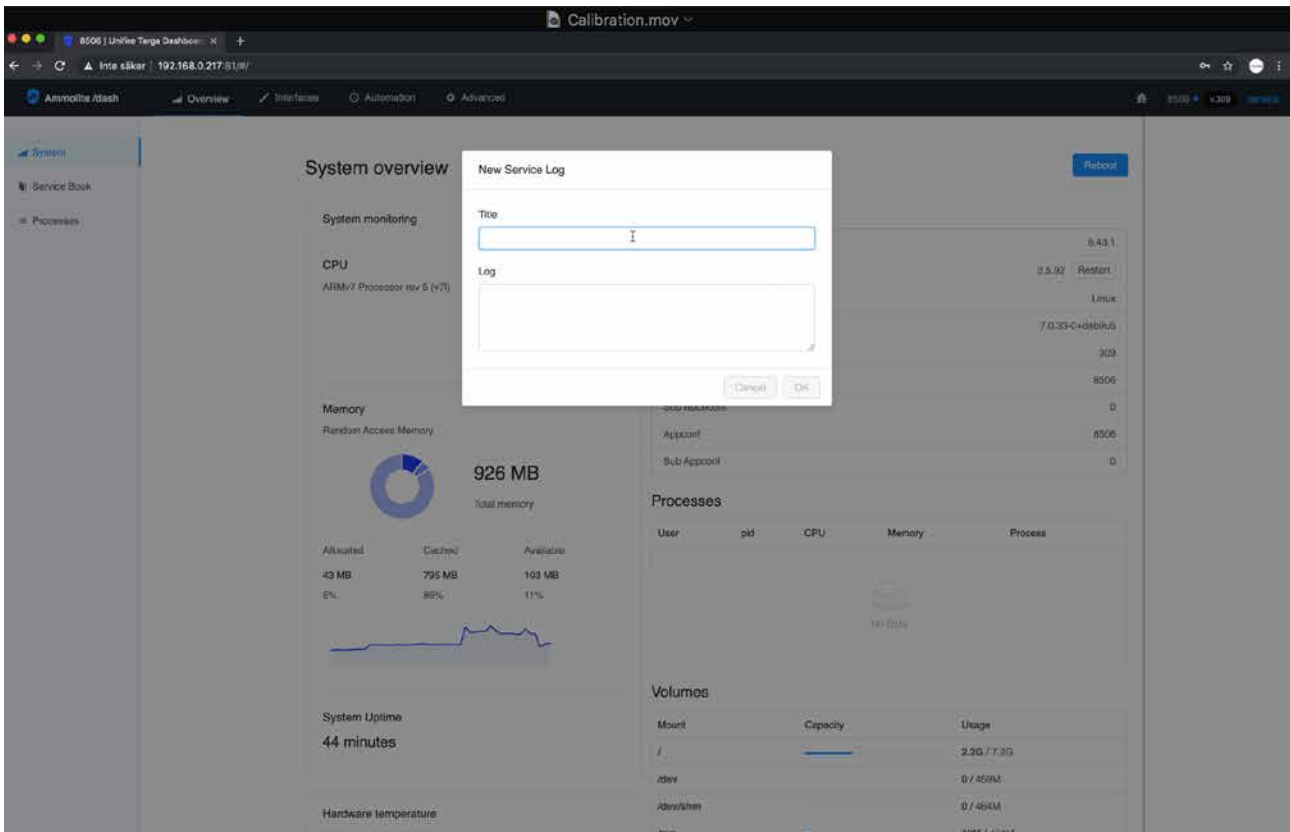

5) You are now requested to make a note in the service log.

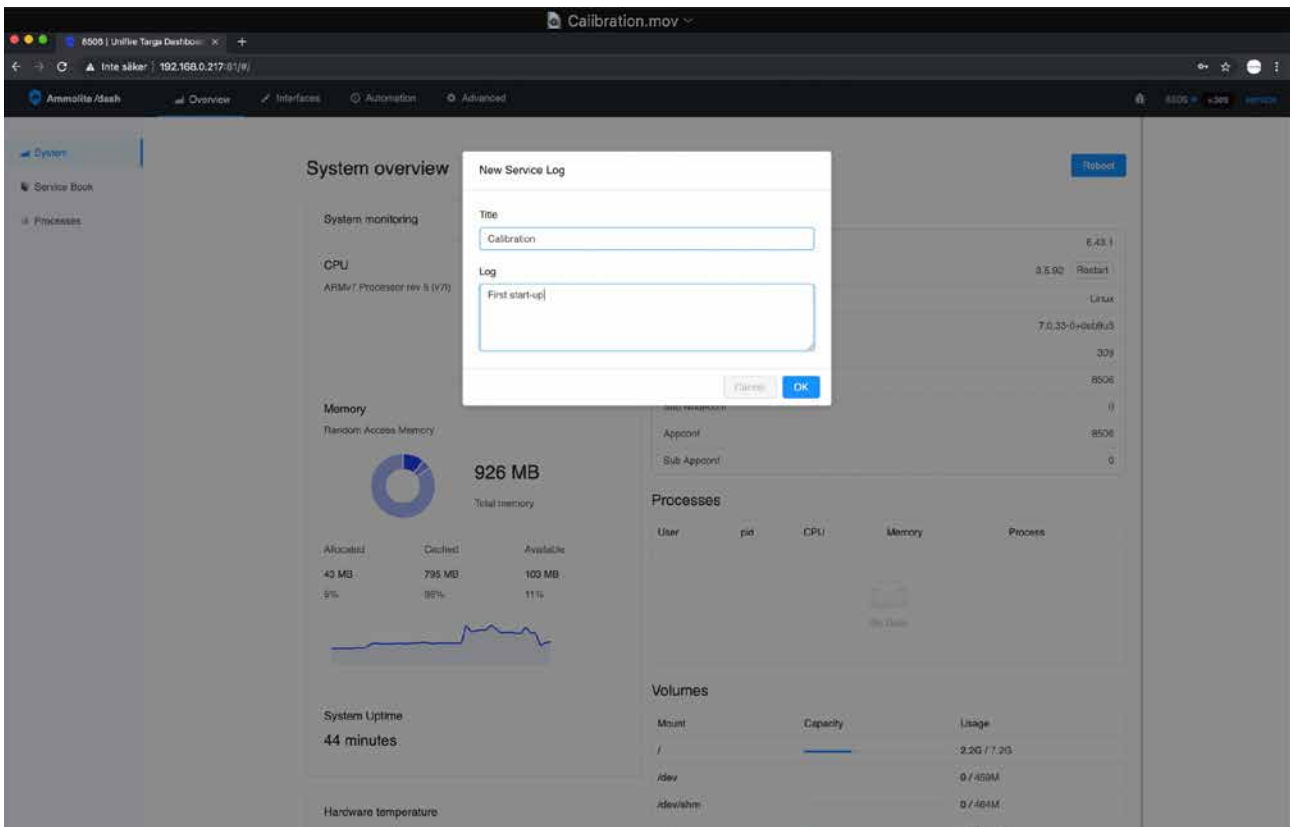

6) So... for the example we write, "Calibration".... "First start up". Any text can be entered. Click OK.

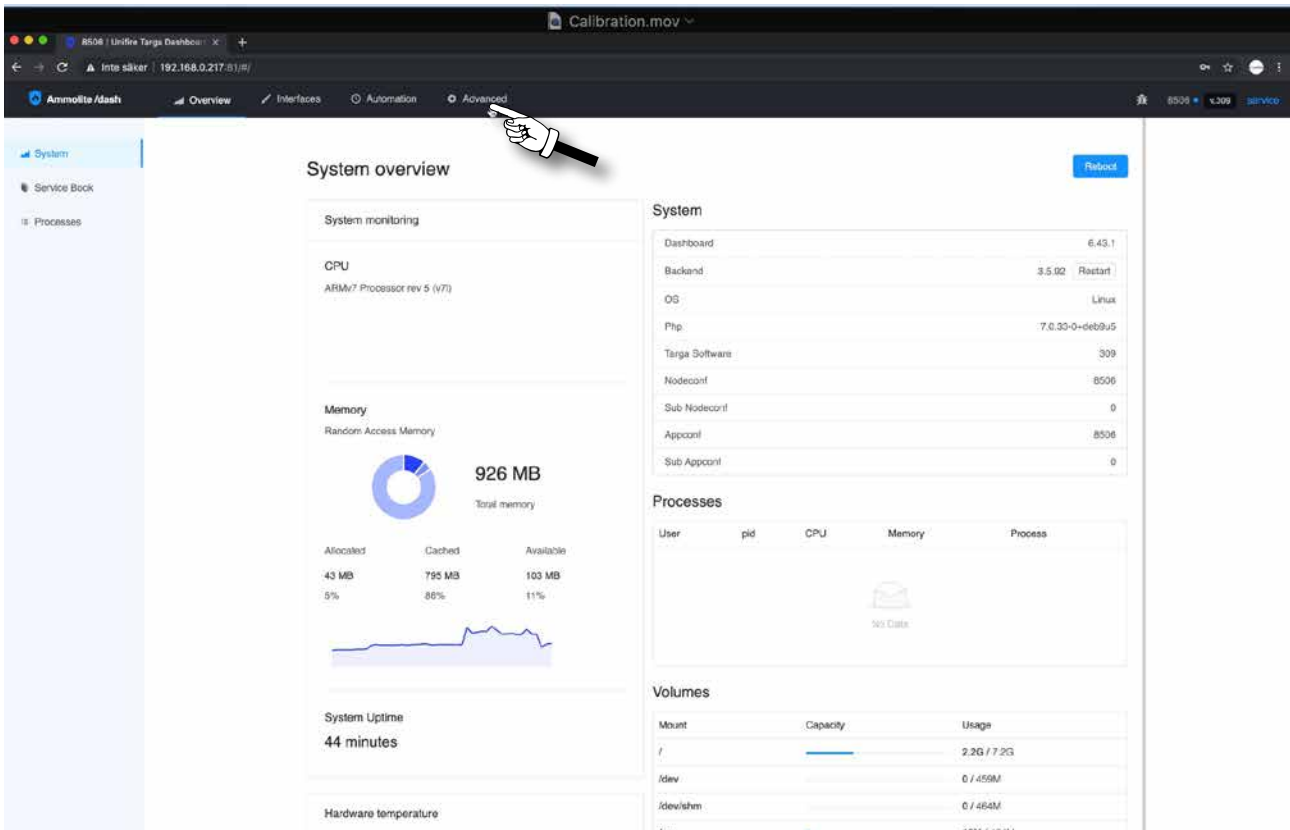

7) This opens up the start page of Ammolite. To initiate calibration of the operating range, click “Advanced”.

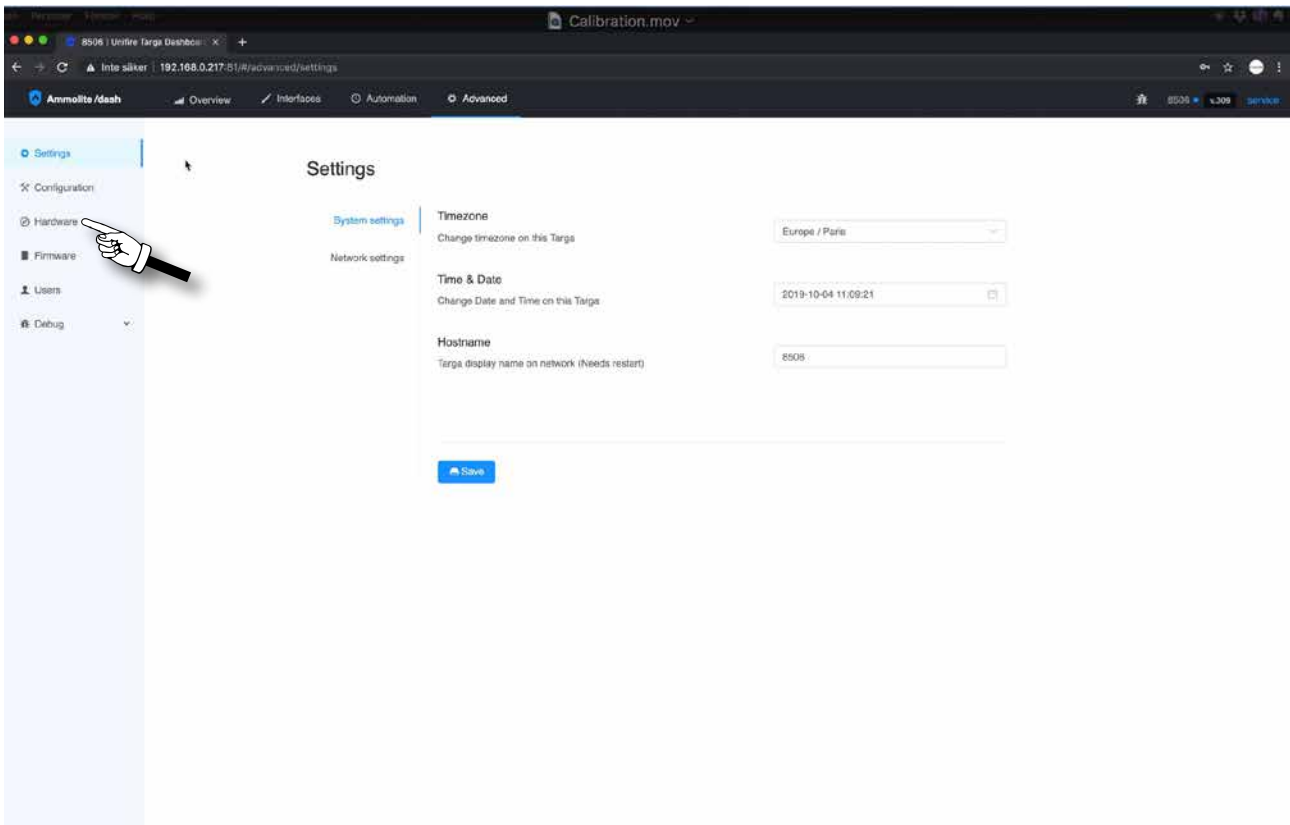

8) This opens up the section Advanced settings. Next click “Hardware”.

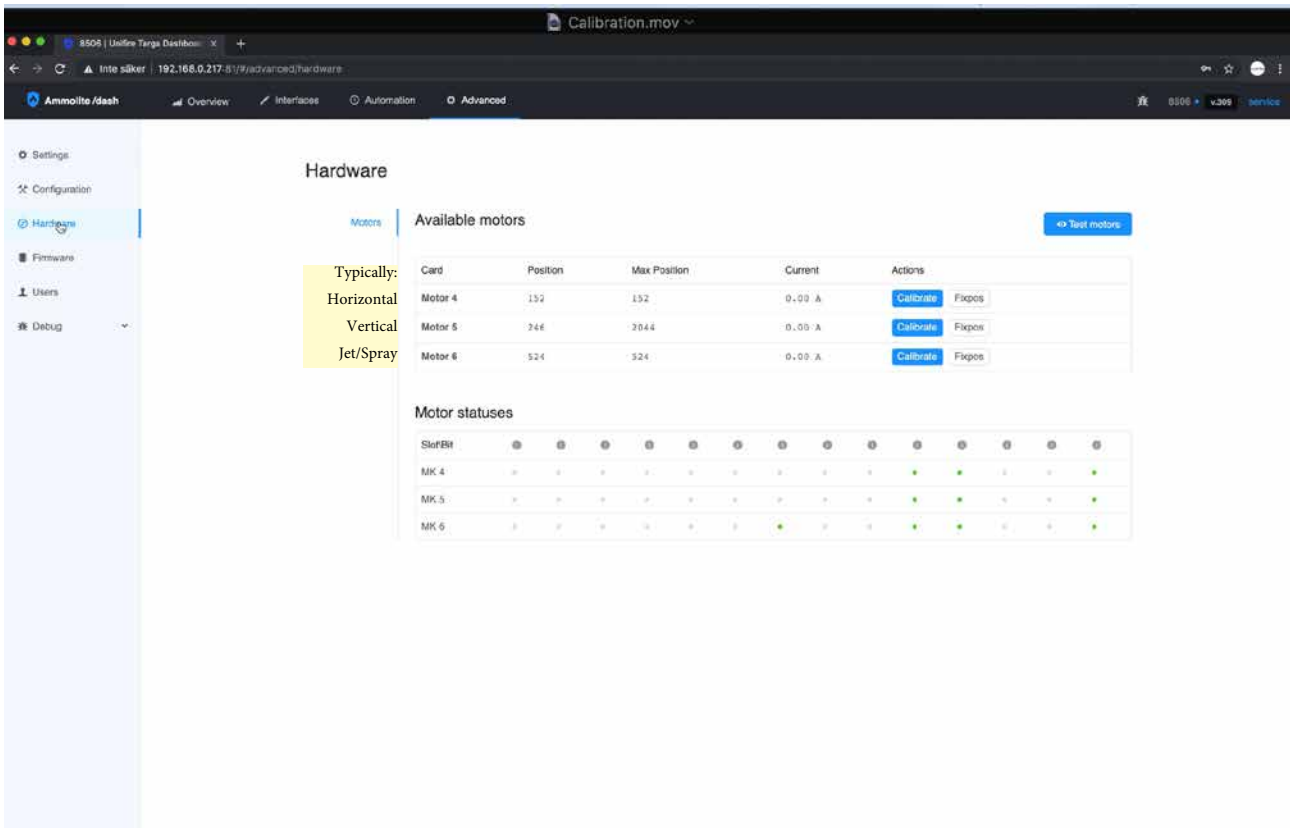

9) This opens up the Motor page. You can read the position of the motors, calibrated max, actual real time current draw (A), and Motor Status. MK4 is usually horizontal, MK5 usually vertical, and MK6 usually nozzle jet/spray)

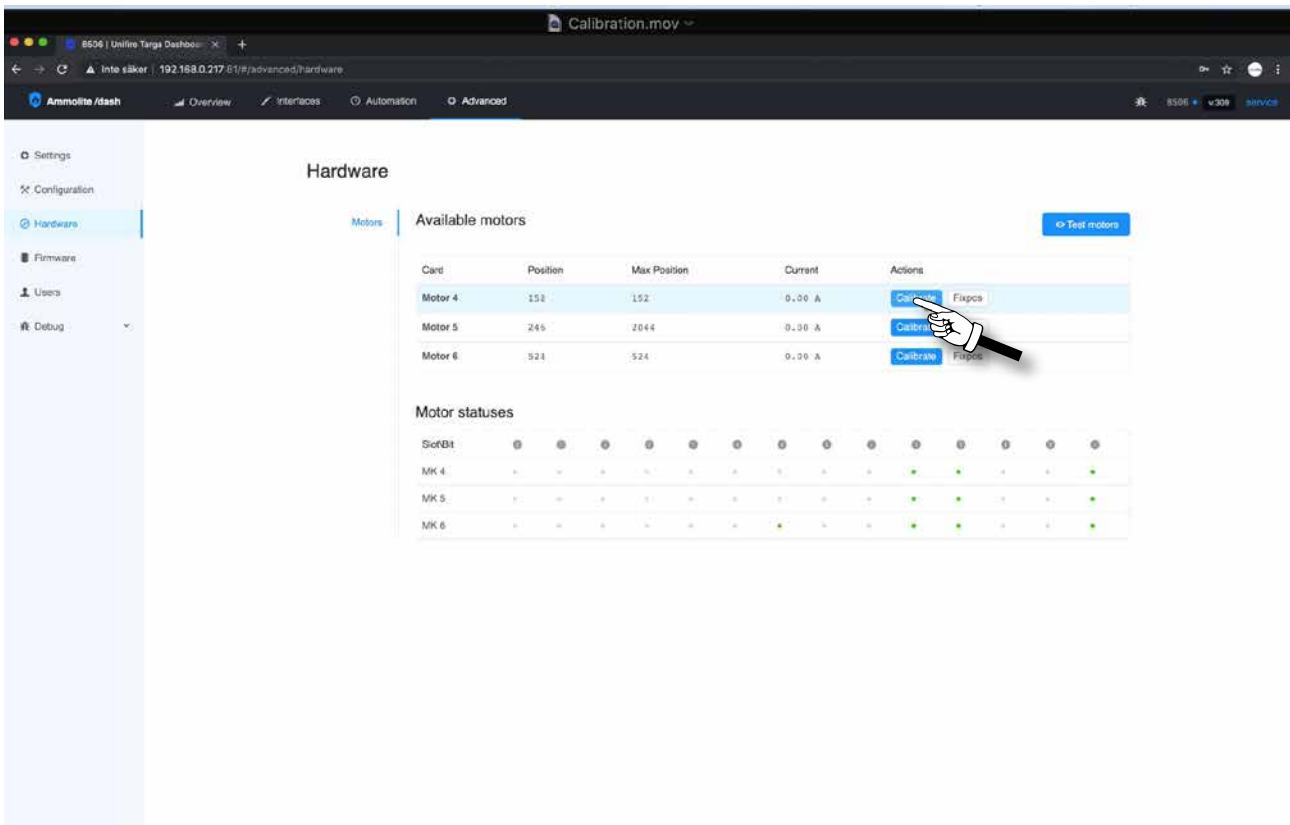

10) To calibrate Motor 4 (horizontal), click “Calibrate”.

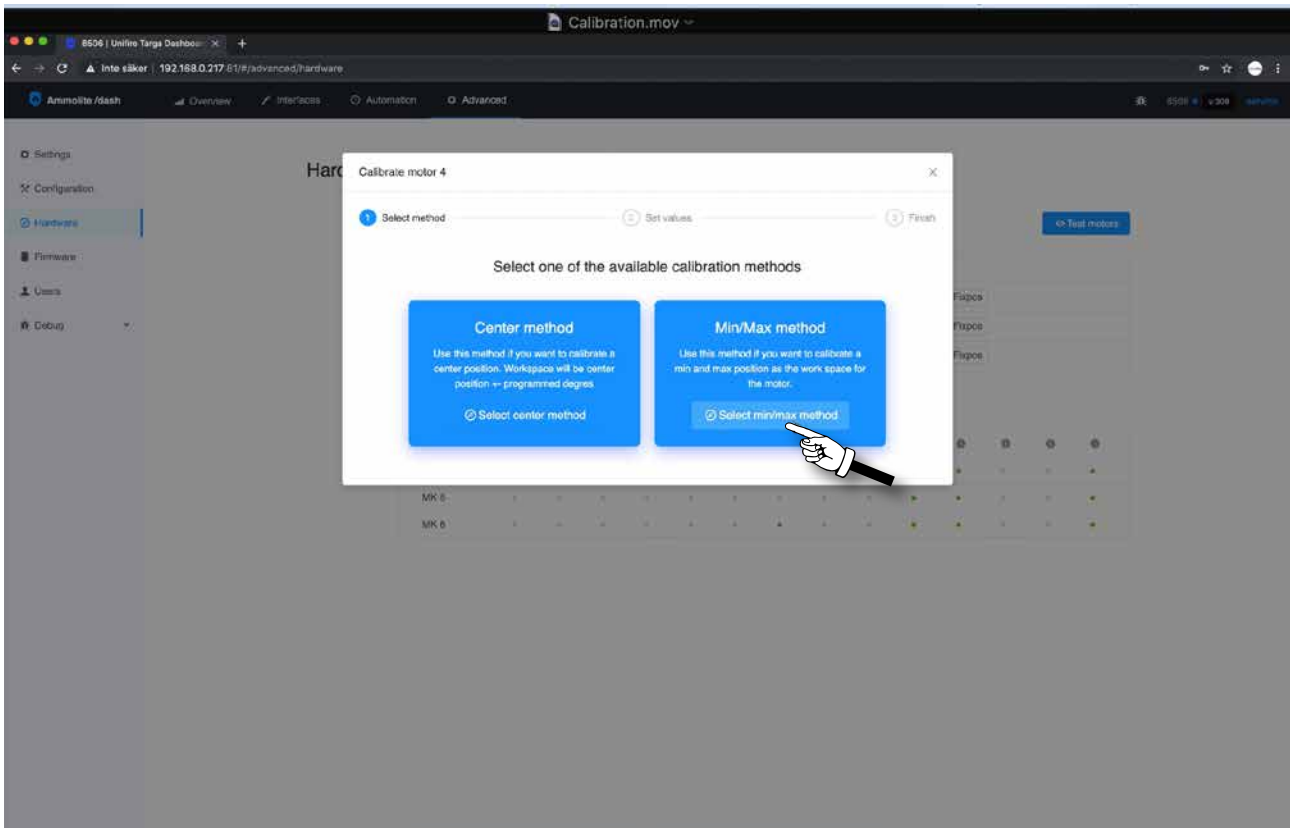

11) Select Min/Max method that allows you to freely select any operating range. (Center method is used only for special applications when the operating range is preset in the software)

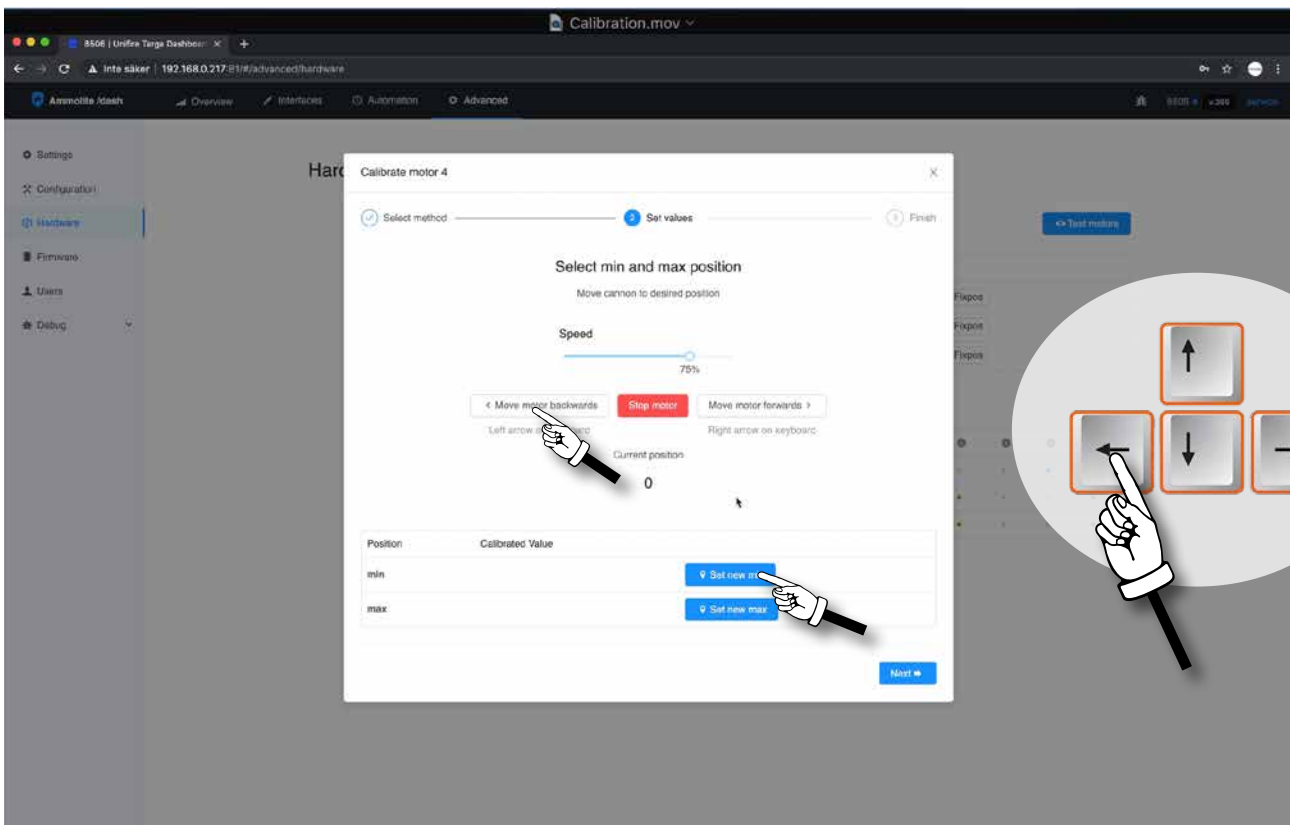

12) Run the motor to the required Min position (left arrow), by using either the buttons on the screen (for tablets), or using the right/left arrow key on your PC Keyboard. Once you have the position, Click “Set new min”

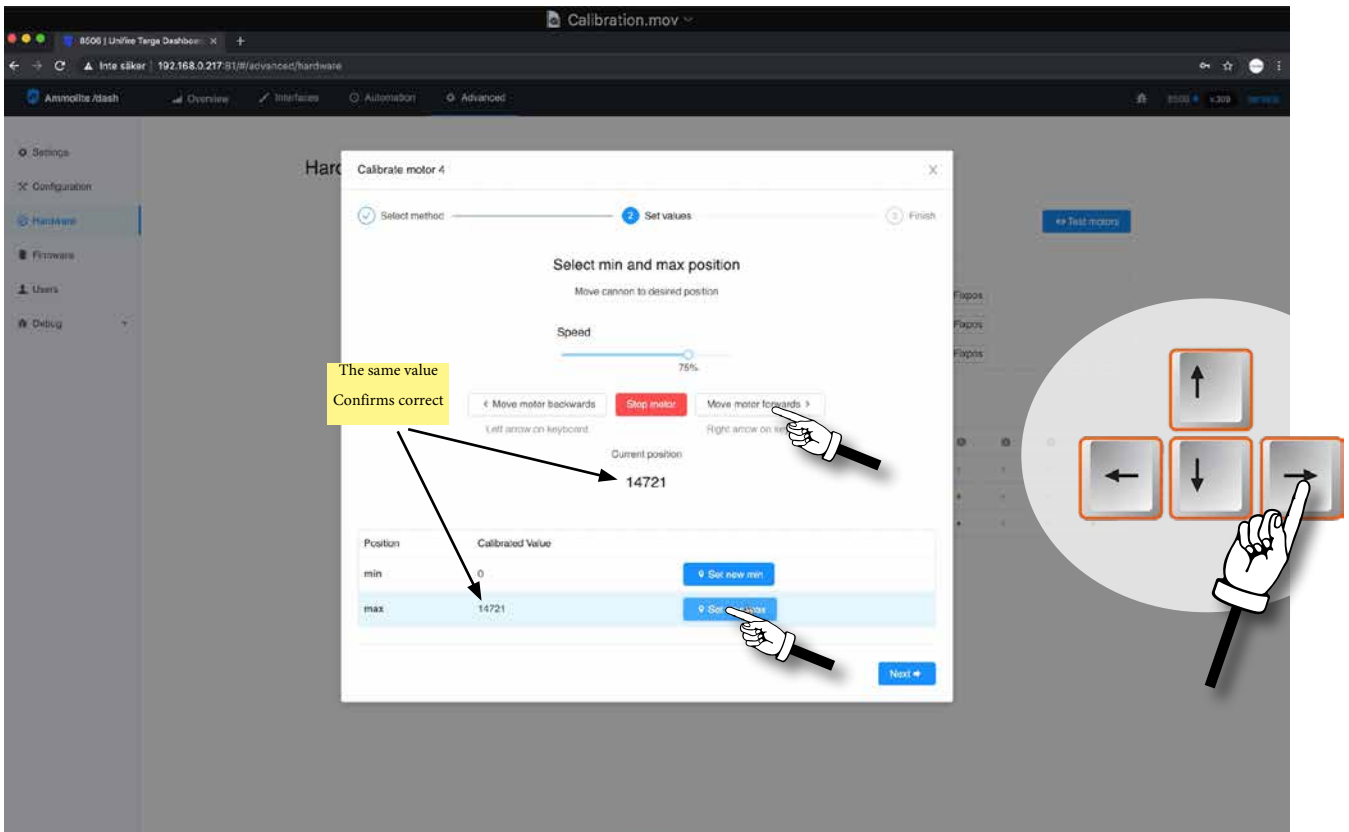

13) Run the motor to the required Max position (right arrow). Now the “Current position should read a value typically between 2 000 and 50 000. Click set new Max.

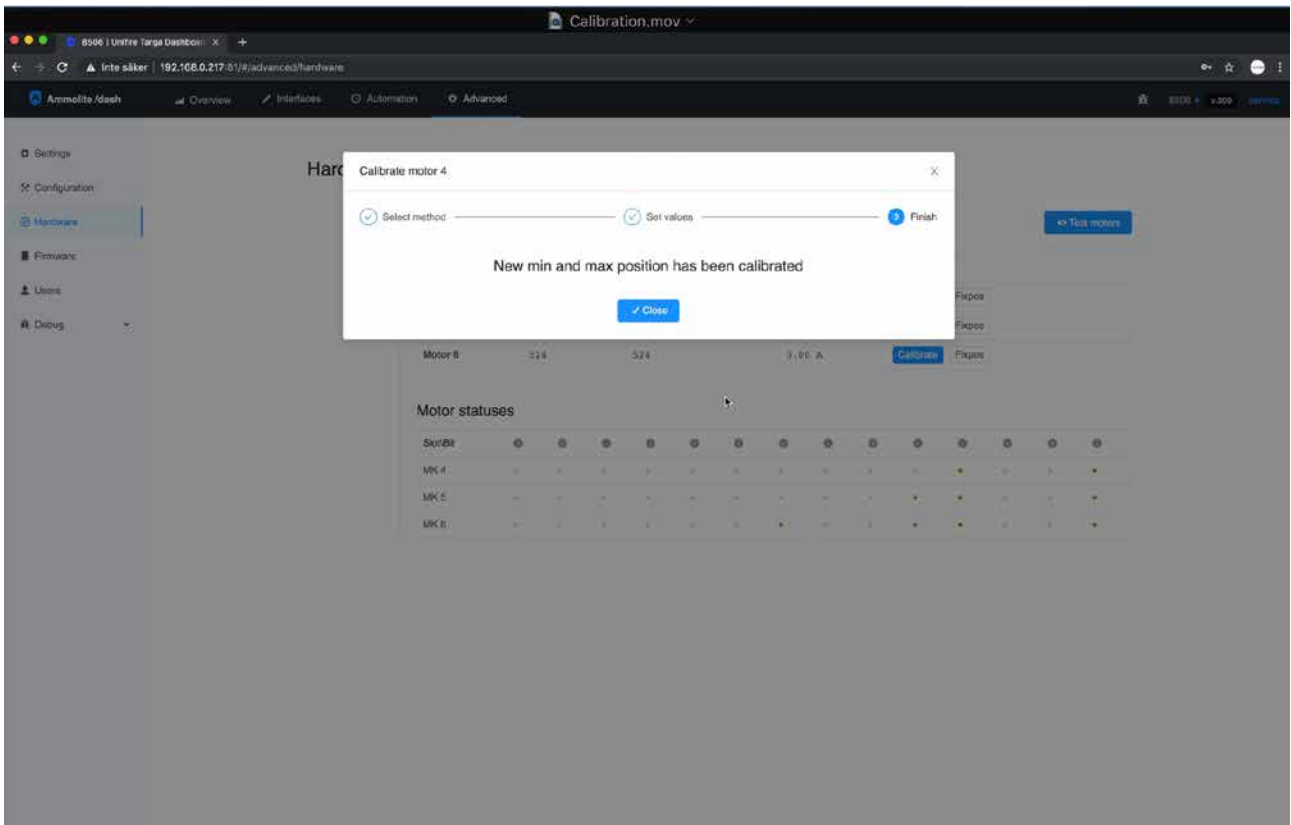

14) Next, you see this notice, confirming successful calibration.

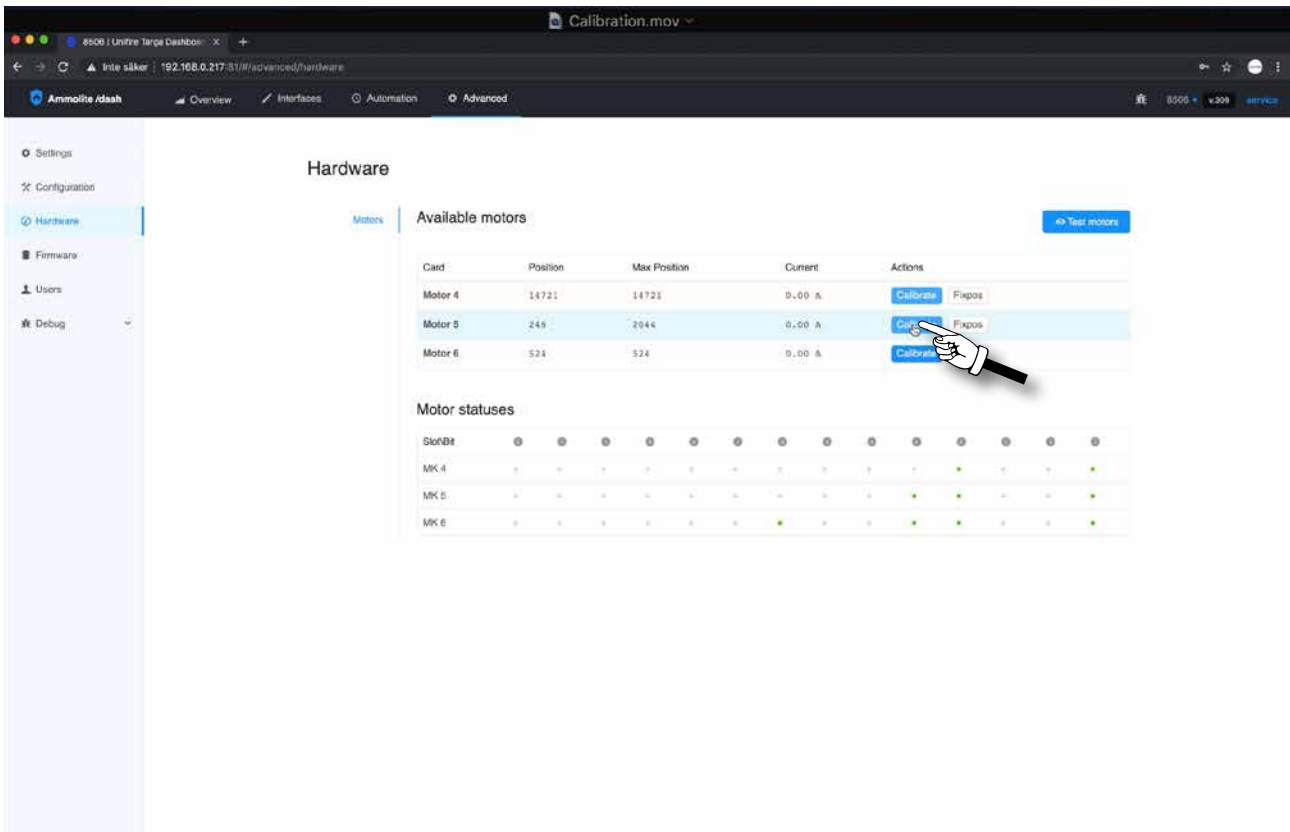

15) Repeat steps 10 - 15 for Motor 5 (vertical)

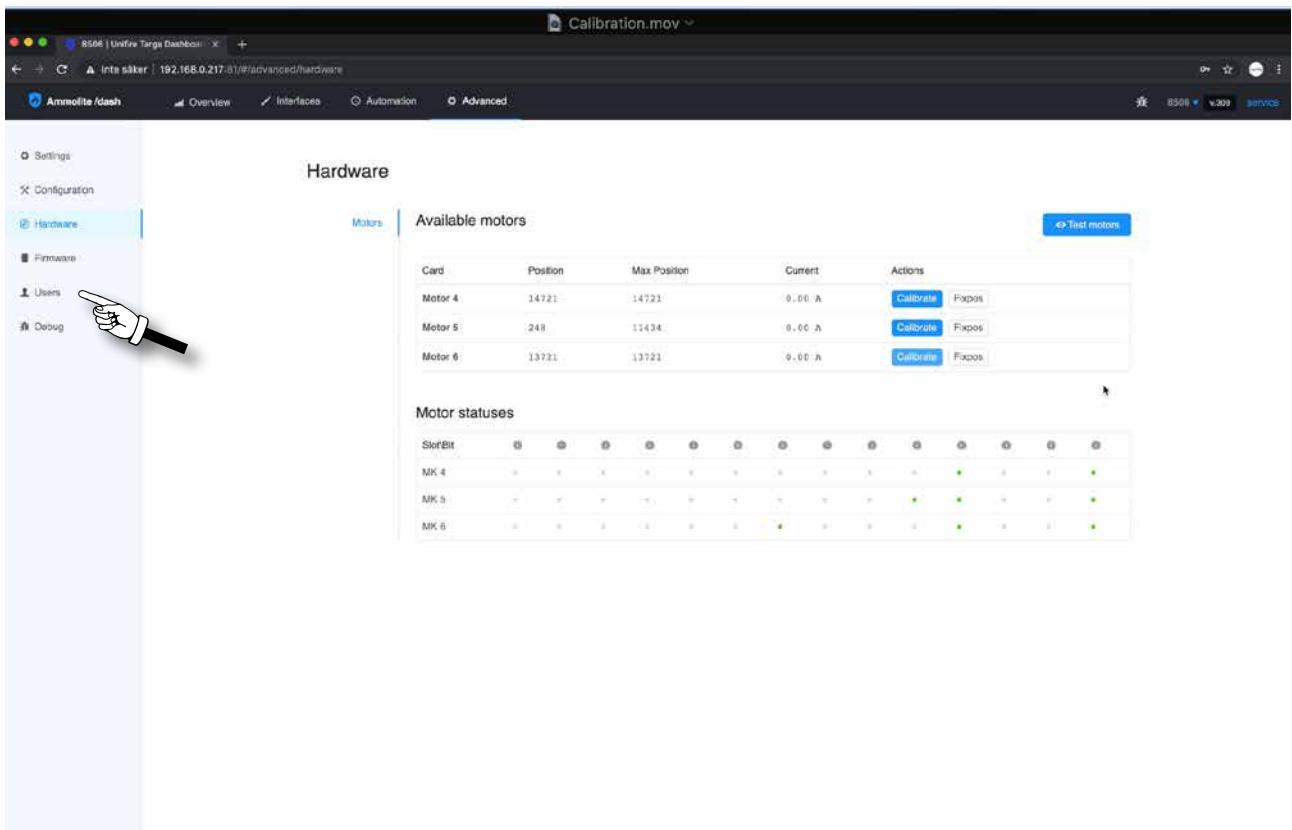

16) Calibrate Motor 6 (nozzle jet/spray) in the same manner as you did the other motors, but follow the instructions in step 17 on the next page

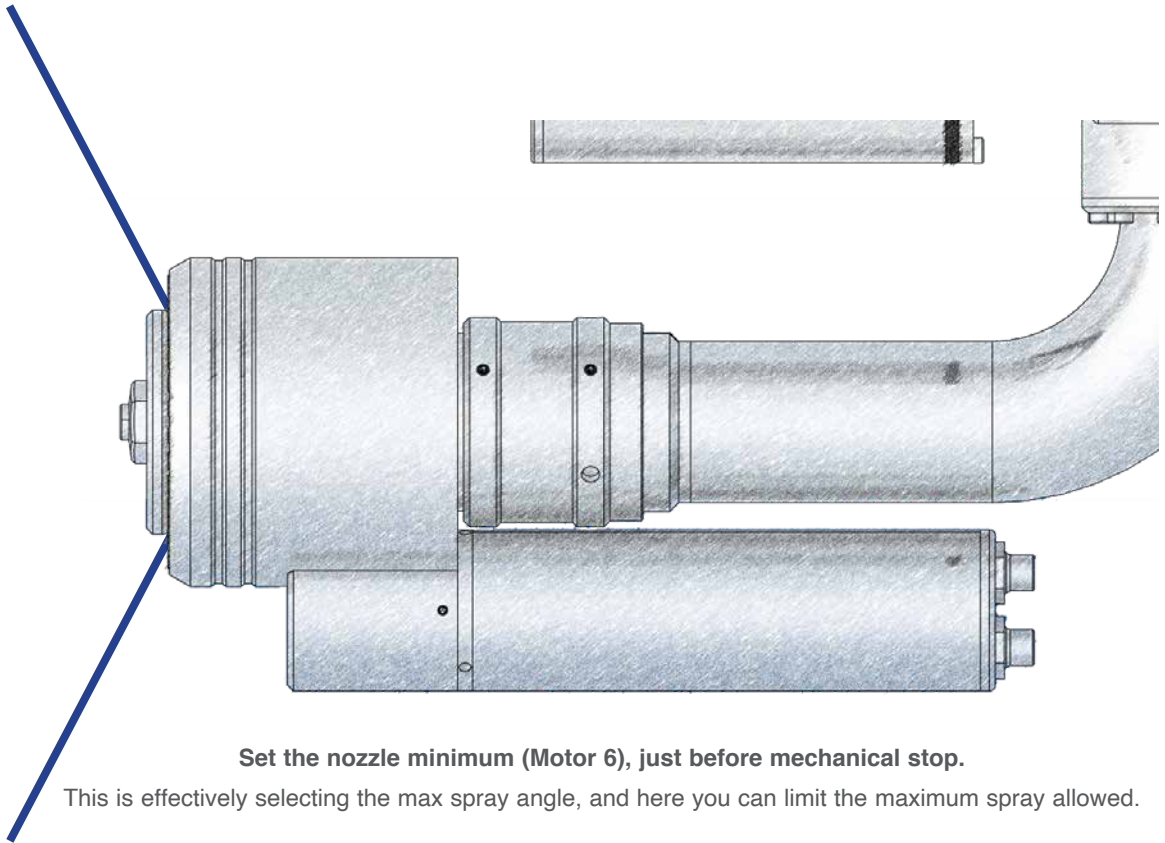

Set the nozzle minimum (Motor 6), just before mechanical stop.

This is effectively selecting the max spray angle, and here you can limit the maximum spray allowed.

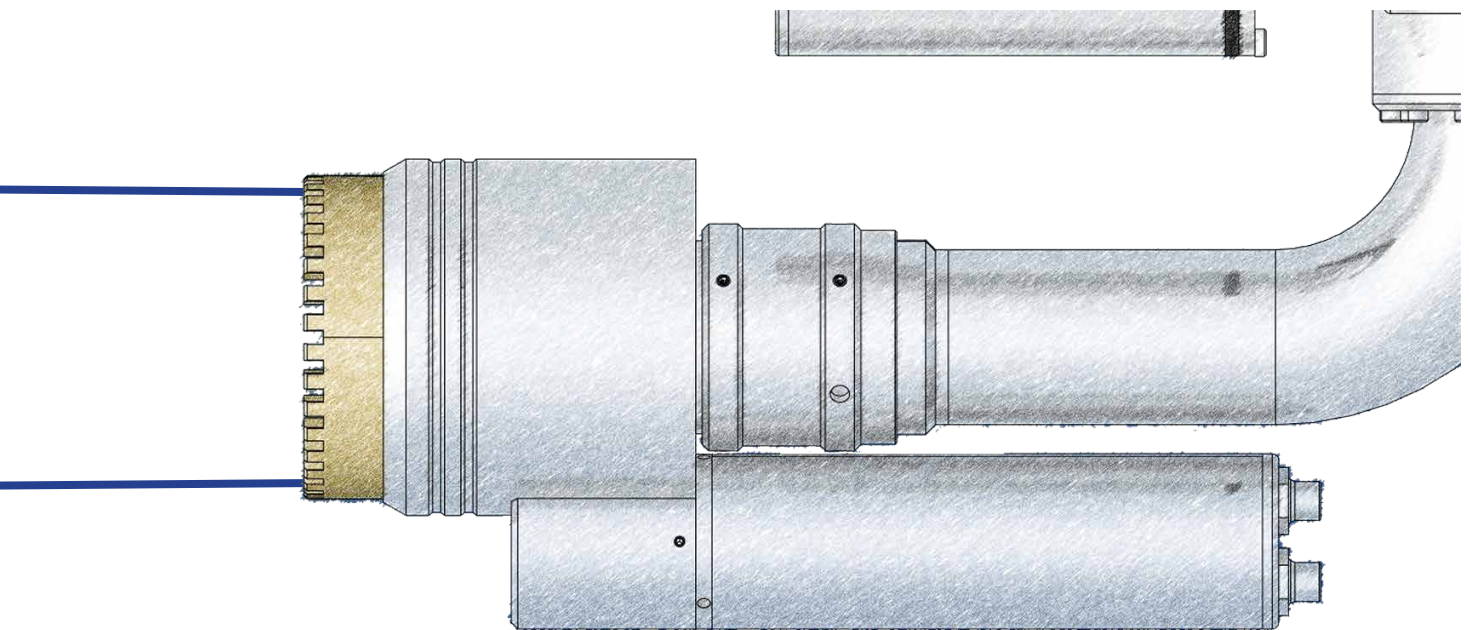

Set nozzle maximum (Motor 6), just before mechanical stop.

This is effectively selecting the straight stream.

Here you can block the straight stream by setting the

Maximum to - say - 10 ° spray, and thereby avoid a straight steam.

This is useful when the required reach is short, and you want to avoid a hard-hitting straight steam all together.

17) Calibrate Motor 6 (jet/spray nozzle) as Motor 4 and Motor 5

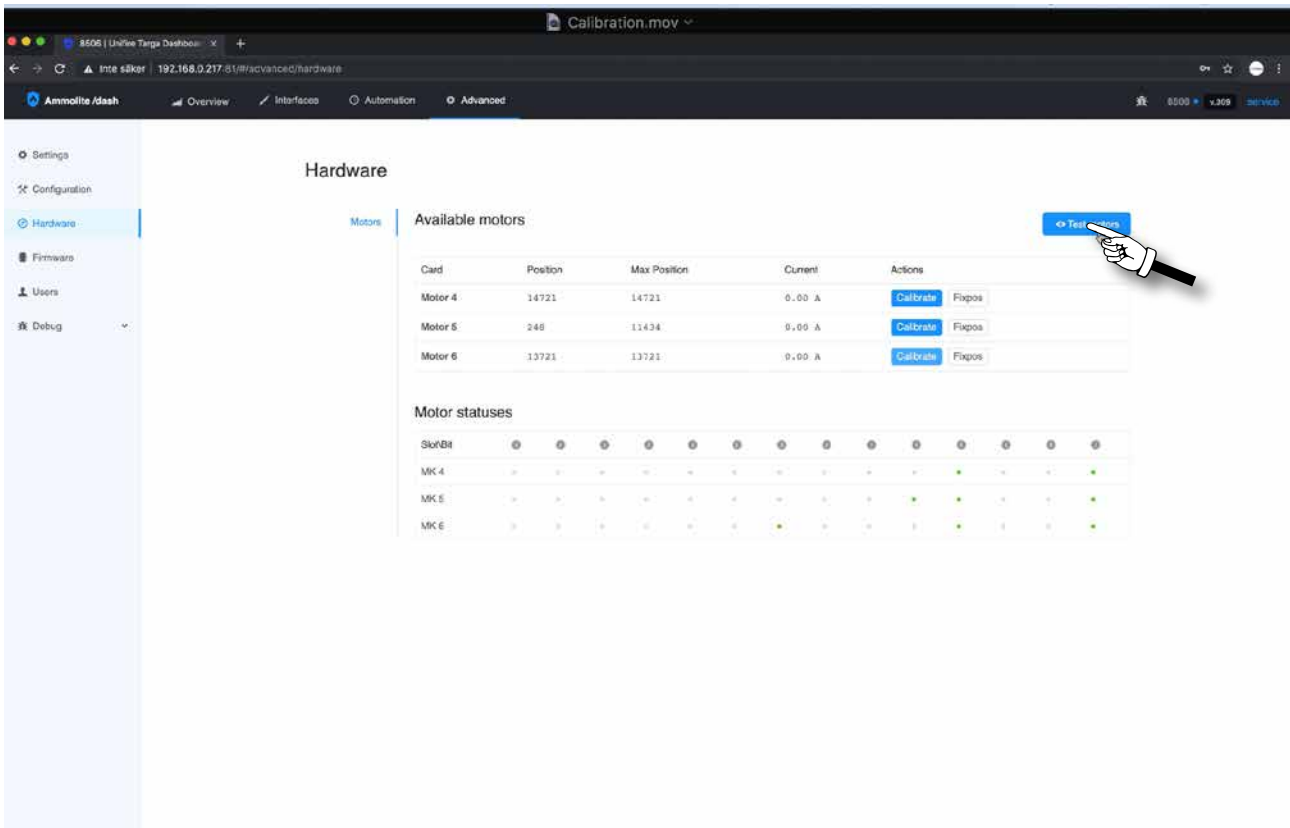

18) Next you can test the motors and calibrated range directly form your PC. Click “Test motors”.

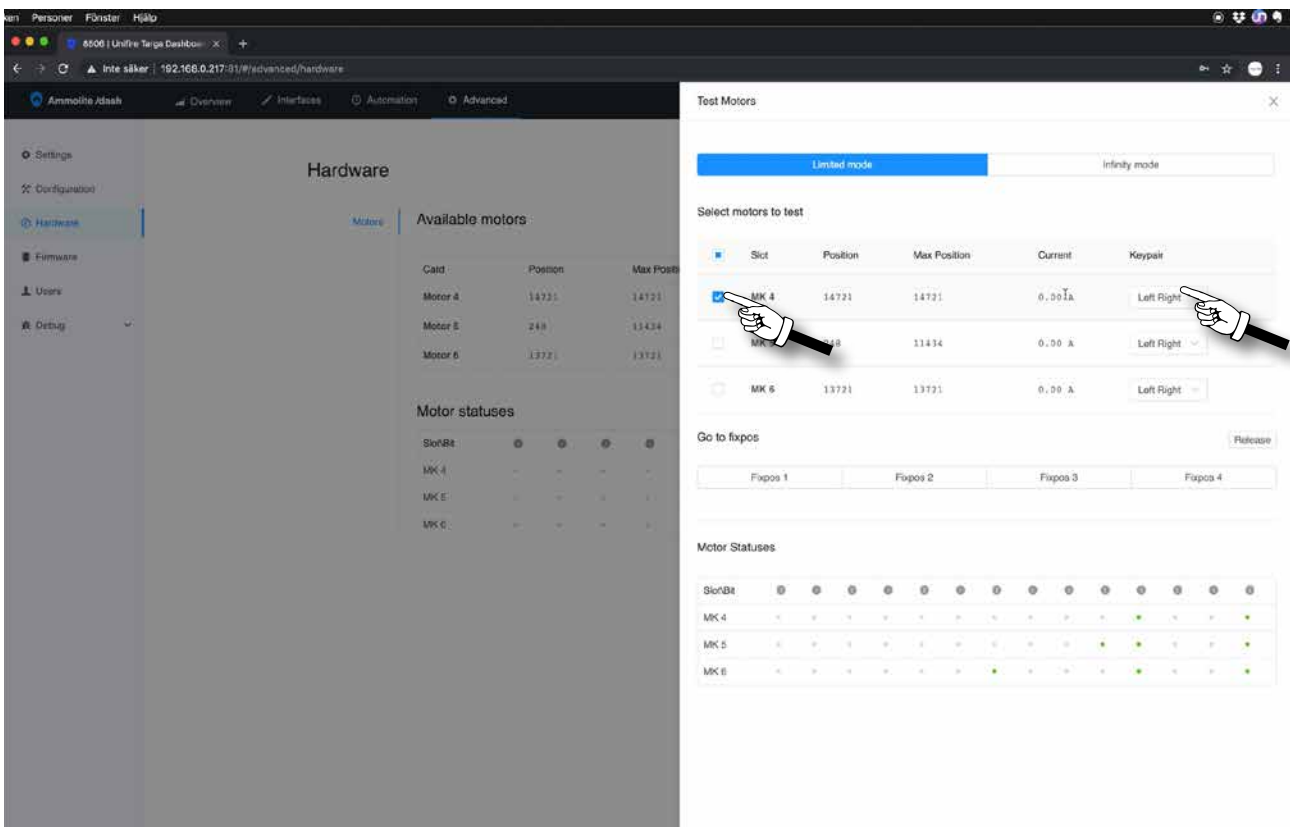

19) Check the box for each motor you want to run.

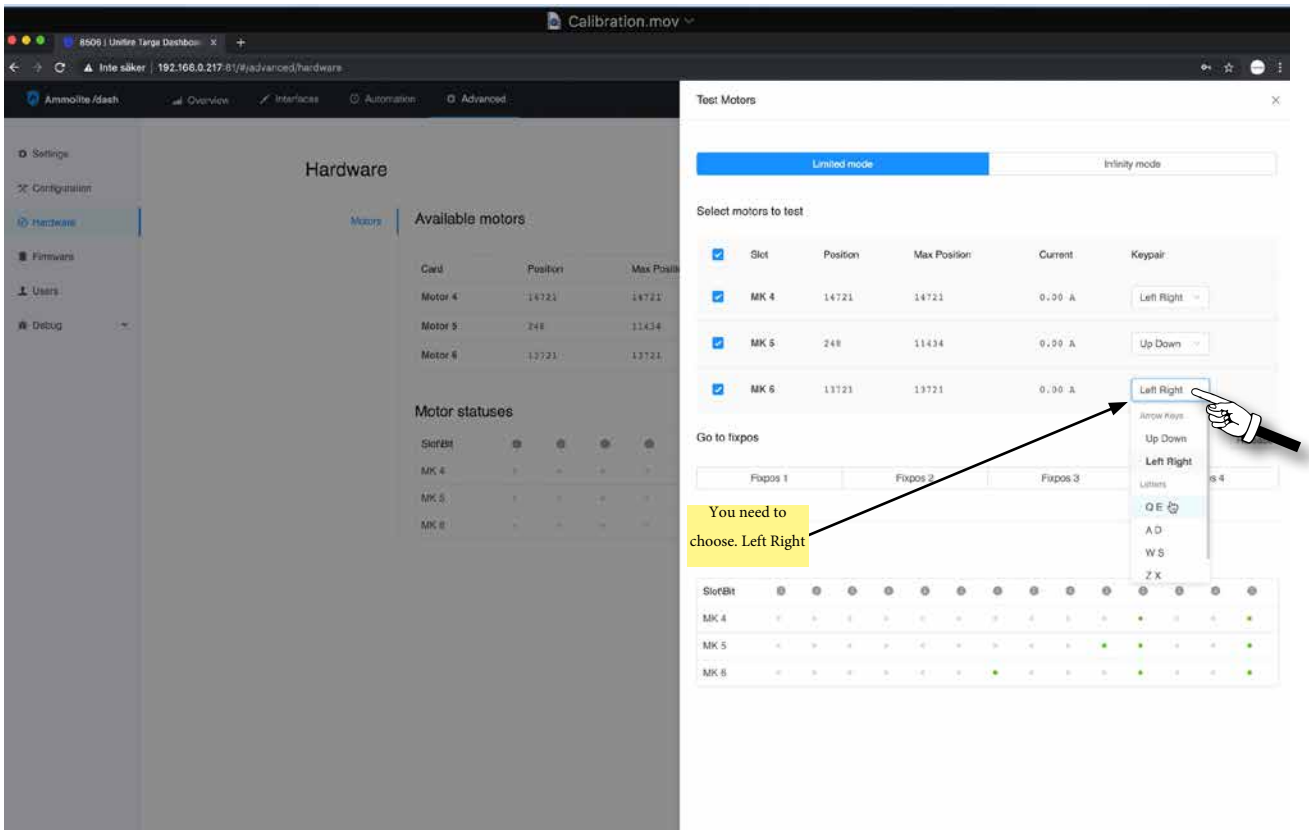

20) Then actively choose key pair. (This must be done.)

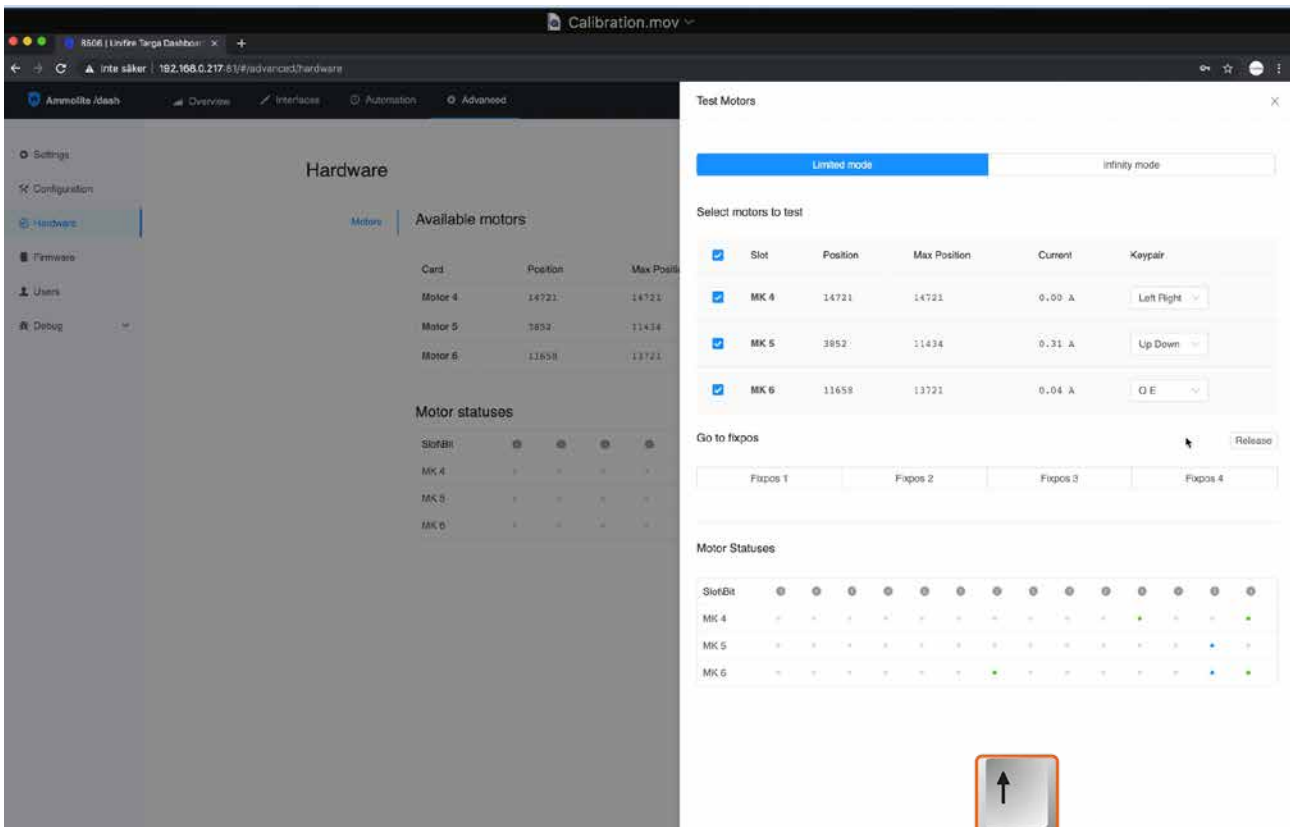

21) Now you can run the motors with the selected key pair.

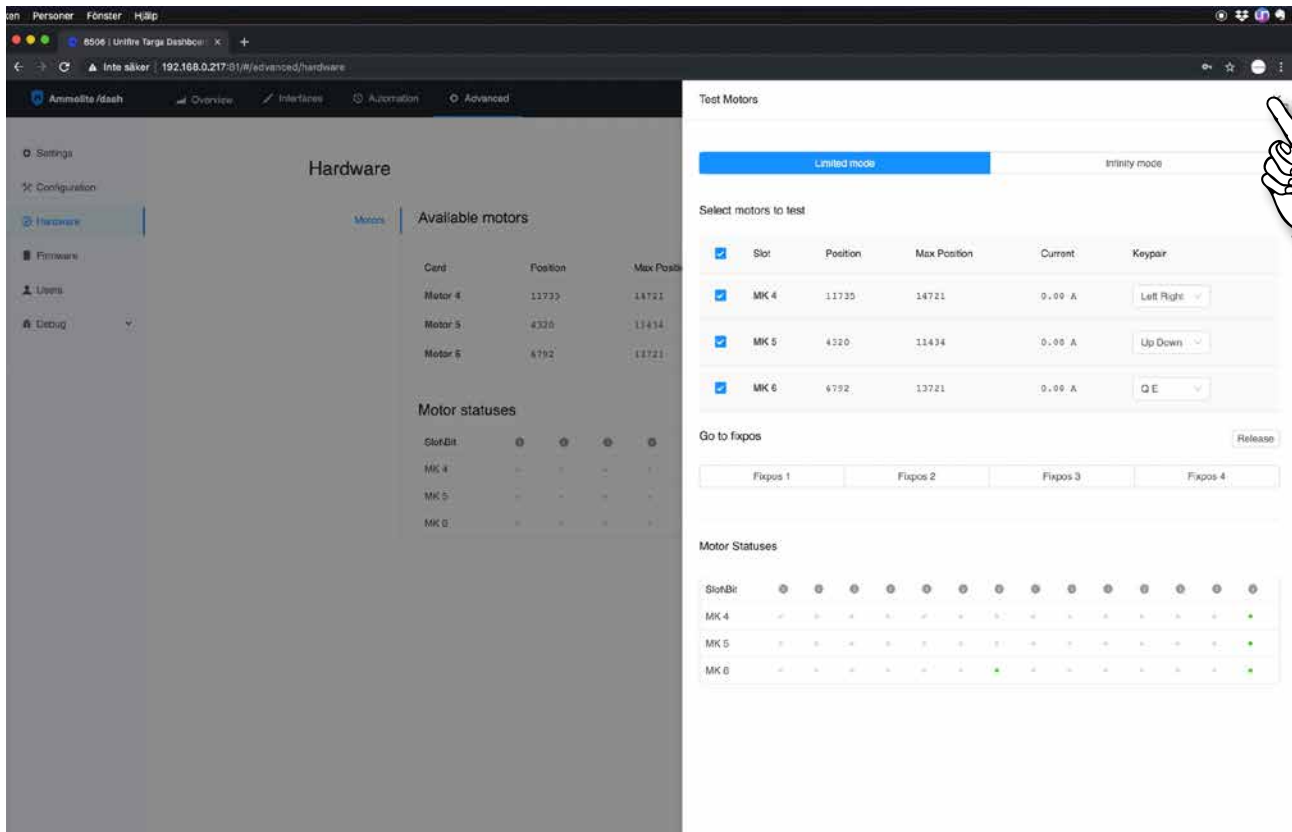

22) Calibration is now complete and you can exit Test Motors and Ammolite.



TECHNICAL SPECIFICATIONS SYSTEM COMPONENTS



FORCE 50 QUICK SPECIFICATIONS

2" ROBOTIC NOZZLE

Max Flow: 2 100 liters (555 gallons) per minute; 126 m³/hr

Type:	Remote Controlled	
Material:	Stainless Steel 316L	
Range of Motion:	360° rotation / 180° vertical movement	
Base Connection:	2" Male BSP or flange (ANSI, DIN, JIS)	
Nozzle Tip Connection:	2" Male BSP	
Motor Type:	24V Brushless DC (BLDC)	
Certificates:	Bureau Veritas (BV) Type Approval / CE Marked / Manufactured at ISO 9001:2015 Certified Facilities	
	Metric	Imperial
Int. Pipe Diameter:	50 mm	2" inches
Dimensions (w/ Integ nozzle):	25 x 35 x 58 cm	9.8" x 13.8" x 22.8" inches
Weight (w/ Integ nozzle):	19 kg	42 lbs
Max. Flow:	2 100 lpm	555 gpm
Max. Reach:	65 meters	71 yards
Max. Working Pressure:	12 bar	174 psi
Nominal Operating Pressure:	10 bar	145 psi

FORCE 50 - DETAILED SPECIFICATIONS

ITEM / FEATURE	DESCRIPTION
<p>Force 50 BLDC Robotic Nozzle Chassis:</p>	<p>2" electric 24V brushless motor (BLDC) robotic nozzle (a.k.a. "remote control monitor" or "water cannon") suitable for fire fighting.</p> <p>Made of 316L Stainless Steel (EN1.4404).</p> <p>Robust and suitable for harsh environments.</p> <p>Compatible with use of foam, salt-water, and other harsh agents.</p> <p>Smooth, large (50mm) pipe bends for minimal friction loss.</p> <p>Fully integrated and enclosed stainless steel worm gears, with Bronze (CuSn12) gear wheels.</p> <p>Fully enclosed BLDC brushless motors provide extremely long life, high torque and allow extremely accurate positioning and position feedback.</p> <p>Modular design for capability of changing damaged pipe sections and gear housings.</p> <p>Very low-maintenance; never requires re-greasing.</p> <p>Mass: Approx. 12.5 kg without nozzle tip.</p> <p>Dimensions (w/ Integ nozzle): 25 x 35 x 58 cm.</p> <p>Ambient temperature range: -25°C to +70°C.</p>
<p>Flow Range:</p>	<p>500 to 2100 liters (130 to 555 U.S. gallons) per minute; ; 126 m³/hr).. Integ 50 jet/spray tip is mechanically adjustable to accommodate various flows. JETRANGE 50 tip has interchangeable flow discs to meet your flow requirements</p>
<p>Max Working Pressure:</p>	<p>12 bar</p>
<p>Nominal Operating Pressure:</p>	<p>10 bar</p>
<p>Maximum Reach:</p>	<p>Approximately 65 meters at 2000 liters per minute at 10 bars (71 yards at 530 gpm at 145 psi) in jet stream mode. Actual results can vary significantly depending on a number of factors (wind, piping, valves, pump, etc.)</p>
<p>Maximum Range of Motion:</p>	<p>360° horizontal; 180° vertical (+/- 90° from horizontal). Range can be easily set to any range desired. (May be limited if used with POINTER controller to 270° horizontal / - 20°/+ 70° or other custom specification. Inquire to learn more.)</p>
<p>Movement Velocity (Speed):</p>	<p>Standard: 24°/sec. rotational; 12°/sec. vertical Optional High Speed: up to 70 or 360 °/sec.</p>



TARGA™ PLC SPECIFICATIONS

Unifire's Revolutionary PLC for Total System Control

Models:	TARGA1, TARGA2, TARGA3, TARGA4, TARGA5 & TARGA6 (digit represents # of installed BLDC driver cards)
Power:	24V DC / 20 Amps
Weight:	1 kg / 2.2 lbs
Dimensions:	225 x 225 x 125 mm / 8.9" x 8.9" x 5" inches
Communication Protocols:	2 x CAN 2.0 29-bit header (UniCAN) 125.250.500 kB/s, RS232, RS485 (Modbus, DMX, etc.)
Physical Layer Protocols:	USB, Ethernet (TCP/IP, web socket), others available per customer requirements.
BLDC Motor Driver Card Slots:	6 (each with 2 digital inputs)
Inputs:	4 digital inputs (NPT) + 2 per installed motor driver card, 6 analogue inputs (4-20 mA or 0-5V), expandable & customizable to customer requirements
Outputs:	8 digital outputs, of which 4 can be set to PWM, expandable to customer requirements
Connector Types:	M12 A/B coded, 4P, 5P, 8P, 12P
Certificates:	CE Marked, Manufactured at ISO Certified facilities.

TARGA PLC DIMENSIONS



X-TARGA



RITTAL IP66 Steel
Plate Cabinet

X-TARGA-S



Weidmüller IP67
Stainless Steel cabinet

X-TARGA™ & X-TARGA-S

Unifire's Revolutionary, Industrial & Marine PLC for Total System Control

The X-TARGA is Unifire's revolutionary TARGA PLC (Programmable Logic Controller), mounted in one of two choices of IP66 cabinets, both designed for the harshest environments and power supply from 110 to 230 V AC at 50 or 60 Hertz., for the total, flexible control of Unifire's advanced robotic nozzle systems and a virtually-endless variety of other system peripherals and components. The unique TARGA system allows users to simply and economically tailor water cannon systems to their individual needs. From basic, low-cost, stand alone installations, to highly sophisticated and integrated systems.

Both cabinet types are IP66 rated and designed for the harshest environments, both on- and off-shore. The X-TARGA comes standard with a built-in power converter from 110 to 230 V AC at 50 or 60 Hertz to TARGA's native 24VDC / 20 Amp requirement. The mounted TARGA (see TARGA section of this brochure) is a scalable system platform that supports up to six BLDC motors and numerous analogue and digital inputs and outputs. The Unifire X-TARGA PLC controller for robotic nozzles, valves, lights, peripherals, automatic systems, system integration, and much more.

2019 technology allows our customers to control systems from their phone, tablet and computer, from anywhere in the world. Network systems together and control from a central control station, and even monitor the system status, learn of any component failures, and upload system software updates or system function changes requested from Unifire.

X-TARGA(-S) PLC SPECIFICATIONS

Models:	X-TARGA & X-TARGA-S (each followed by a number 1-6. representing the quantity of installed BLDC driver cards)
Power Input:	110/230 V AC, 50/60 Hz (built-in converter to 24VDC / 20 Amps)
Approximate Weight:	15 kg / 33 lbs.
Cabinet Types:	<p>Model: X-TARGA: RITTAL IP66 Steel Plate cabinet type: AE 1045.500, Dimensions: 500 x 400 x 210 mm / 19.7" x 15.8" x 8.3" inches, mass: 13 kg.</p> <p>Model: X-TARGA-S: Weidmüller IP67 Stainless Steel cabinet type: KTB MH 453820 S4E1 Stainless Steel 316L Cabinet, Dimensions: 458 x 382 x 200 mm / 18" x 15" x 7.9" inches, mass: 11.54 kg.</p>
Communication Protocols:	2 x CAN 2.0 29-bit header (UniCAN) 125,250,500 kB/s, RS232, RS485 (Modbus, DMX, etc.)
Physical Layer Protocols:	USB, Ethernet (TCP/IP, web socket), others available per customer requirements
BLD Motor Driver Card Slots:	6 (each with 2 digital inputs)
Inputs:	4 digital inputs (NPT) + 2 per installed motor driver card, 6 analogue inputs (4-20 mA or 0-5V), expandable & customizable to customer requirements
Outputs:	8 digital outputs, of which 4 can be set to PWM, expandable to customer requirements
Connector Types:	M12 A/B coded, 4P, 5P, 8P, 12P
Certificates:	CE Marked, produced at ISO 9000 and 14000 certified facilities
Max altitude	Never install the X-TARGA PLC over 4000 meter above sea level

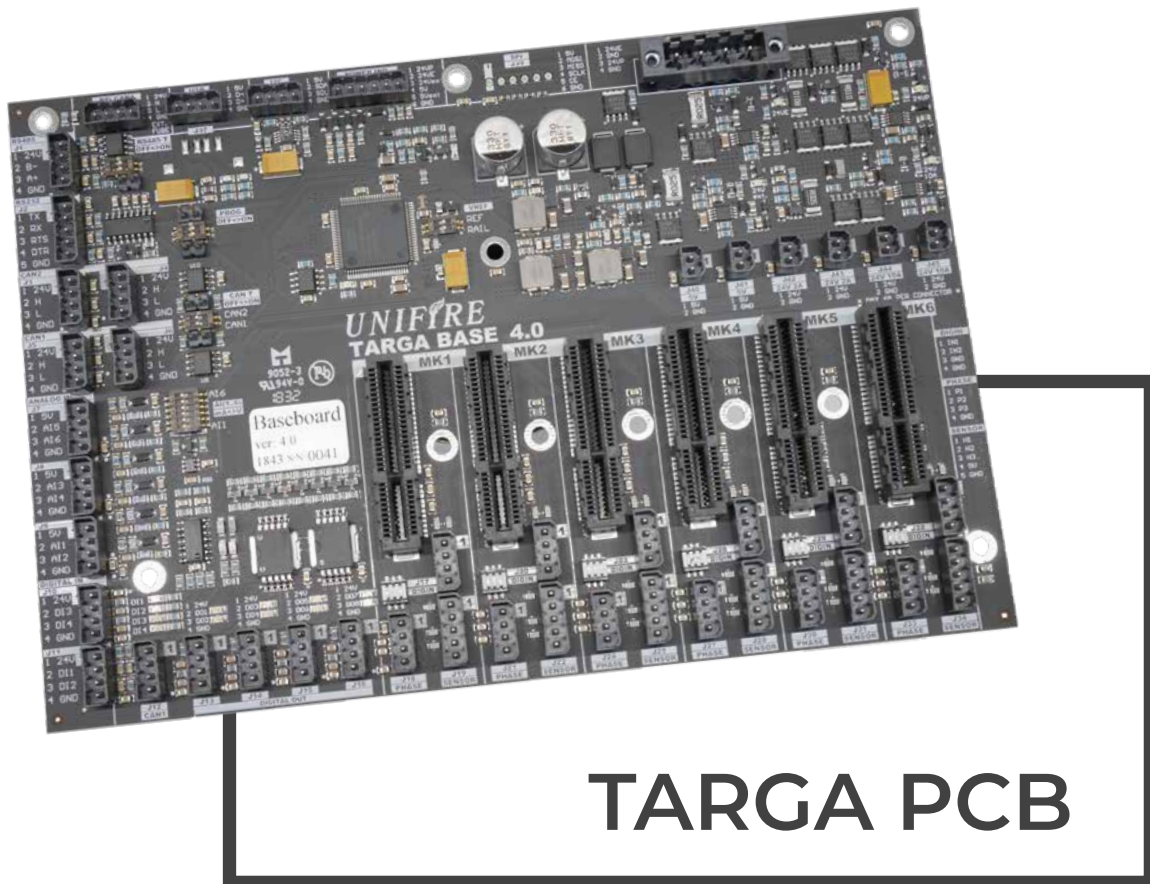

TARGA PCB

Unifire TARGA PCB

Many PLC's (programmable logic controllers) are commercially available on the market, and are used by many of Unifire's competitors.

But Unifire won't settle for standard, off-the-shelf solutions. At Unifire, we think for ourselves. And, we are very demanding.

Commerically-available PLC's are bulky, designed to suit a wide variety of industries and applications, and are therefore over-loaded with bulky electronics, components and software, markedly reducing efficiency, and often failing to include key features Unifire demands for its advanced systems.

That is why Unifire has spent years maticulously designing and improving our own TARGA PCB (printed circuit board), tailor-made for our robotic nozzle systems and their peripherals, and to accommodate technologies yet to come. Our newest generation PCB is cutting-edge technology and provides a huge range of possibilities, accommodates rapid, dynamic technological advances, maximizes efficiency in hardware and software design, and is the perfect solution for total control of our robotic nozzle systems.

Manufactured for Unifire in Sweden at ISO 9001 & 14001 certified, state-of-the-art facilities, side-by-side with electronics for Ericsson, SAAB Space, Volvo, and other industry-leading, highly demanding companies.

When quality matters, look to Unifire.

Features

The Unifire TARGA PCB is loaded with features, including, to name a few:

- 6 BLDC Motor Driver Slots for the control of brushless motors
- A variety of communication protocols, including 2 x CAN 2.0 29-bit header (UniCAN) 125,250,500 kB/s, RS232, RS485 (Modbus, DMX, etc.
- USB, Ethernet (TCP/IP, web socket), others available per customer requirements
- 4 digital inputs (NPT) + 2 per installed motor driver card,
- 6 analogue inputs (4-20 mA or 0-5V), expandable & customizable to customer requirements
- 8 digital outputs, of which 4 can be set to PWM, expandable to customer requirements
- Reserved control pins, allows to work with other control boards
- Comes with development resources and manual (examples in wiringPi/python)

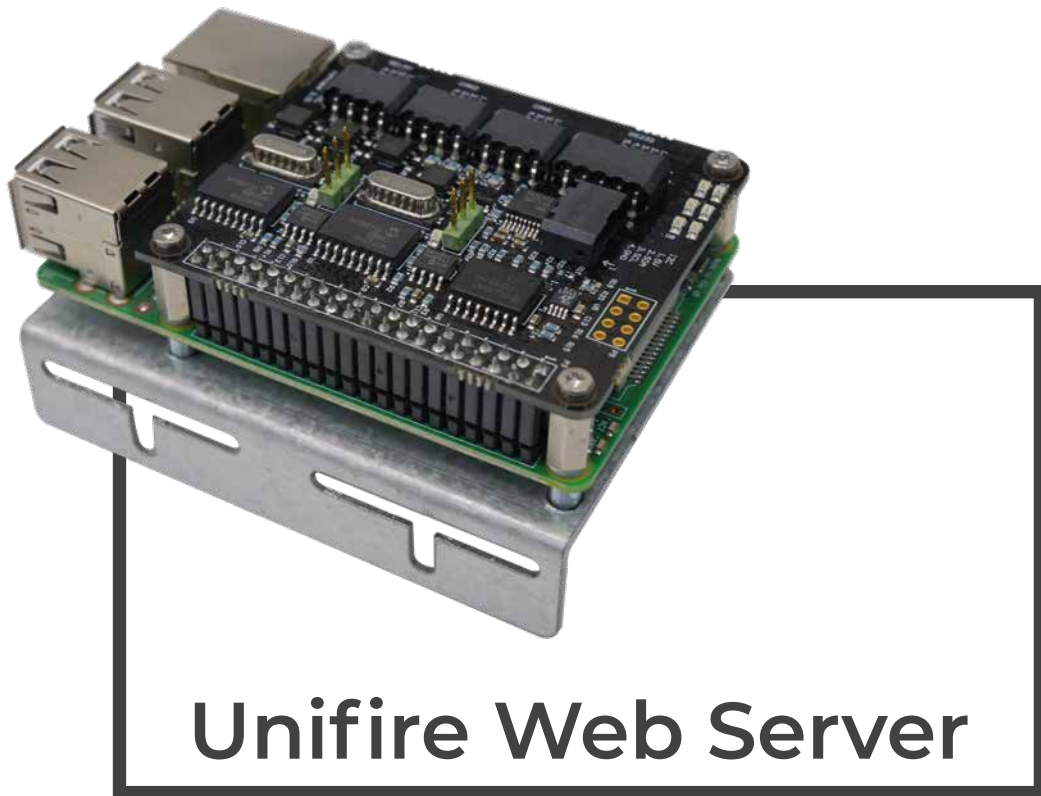

Unifire Web Server

Take Complete Control Of Unifire's Robotic Nozzle Systems From Anywhere In The World, Thanks To Our Web Server— A Full-Blown, Internet-Ready Pc, Built In To Our Targa Plc, That Fits In The Palm Of Your Hand!!

Welcome to the Internet of Things!

The Unifire Web Server is our optional, full-functioned personal computer (PC) add-on to our entire line of TARGA PLC's.

The Unifire web server, combined with our CAN Bus Cape, allows all models of Unifire's TARGA PLC's to come fully online.

Thanks to the Unifire Web Server, our customers have the option of taking full, secure control of Unifire's advanced robotic nozzle systems with our InterAct software and app.

Have a phone? Control our systems. Have a tablet? Control our systems. Have a computer? Control our systems. Got Internet access? Control our systems from anywhere in the world!

Features

The Unifire Web Server is a key component of Unifire's InterAct system. Combined with our CANbus Cape, USB Router and InterAct software and Graphical User Interfaces, adds to Unifire's advanced robotic nozzle systems a host of networking and control capabilities, including over the Internet.

Unifire's already powerful and flexible InterAct graphical user interface can be custom designed to your specific needs, look, function, language and look, with virtually unlimited flexibility to control systems with advanced logic sequences and automated functions.

Specifications

- SOC: Broadcom BCM2837B0, Cortex-A53 (ARMv8) 64-bit SoC
- CPU: 1.4GHz 64-bit quad-core ARM Cortex-A53 CPU
- RAM: 1GB LPDDR2 SDRAM
- Operating system support: Linux and Unix
- WIFI: Dual-band 802.11ac wireless LAN (2.4GHz and 5GHz) and Bluetooth 4.2, capable of running at 2.4GHz and 5GHz.
- Ethernet: Gigabit Ethernet over USB 2.0 (max 300 Mbps)
- Thermal management: Yes.
- Power over Ethernet
- Video: Yes – VideoCore IV 3D. Full-size HDMI
- USB 2.0: 4 ports
- Power: 5V/2.5A DC power input

"Here's to the crazy ones. The misfits. The rebels. The troublemakers. The round pegs in the square holes. The ones who see things differently. They're not fond of rules. And they have no respect for the status quo. You can quote them, disagree with them, glorify or vilify them. About the only thing you can't do is ignore them. Because they change things. They push the human race forward. And while some may see them as the crazy ones, we see genius. Because the people who are crazy enough to think they can change the world, are the ones who do."

— Apple Inc.

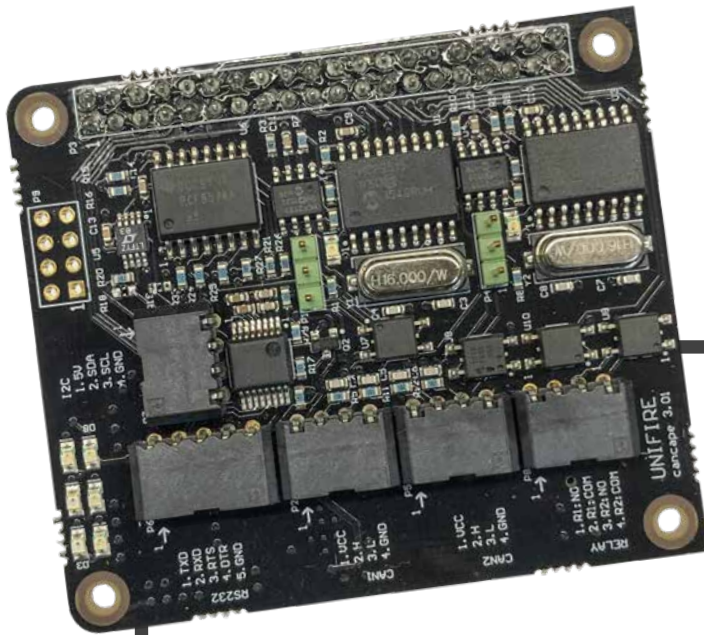

UNIFIRE

CAN Bus Cape

Unifire CAN Bus Cape for Raspberry Pi

Communication Hat with 2x CAN, RS232, I²C and relays.

Technical Overview

The Unifire CAN Cape adds serial networking options to your Raspberry Pi utilizing the GPIO.

The two onboard CAN Bus ports utilize the Microchip MCP2515 CAN controller, accessible per SPI interface, in combination with the Microchip MCP2551 CAN transceiver. 120Ω termination is available by jumper or control over GPIO.

The RS232 port is controlled via the RPi's UART using the MAX3232 line-driver and receiver.

The I²C is buffered by LTC4313 and the two onboard photoMOS relays allow for simple digital control of external equipment. The IO expander for the I²C bus allows for even further expansions.

Onboard is also a DC/DC transformer allowing the CAN cape to supply the RPi with power. PoCAN (Power over CAN) makes this possible.

The CAN cape is also equipped with six blue LED indicators.



UNIFIRE BLDC Driver Card

Unifire BLDC Motor Driver Card

Like all of our electronics, Unifire designed its own BLDC motor driver card to deliver the functionality and efficiency unique to Unifire's robotic nozzle systems.

Unlike competing solutions, Unifire uses 3-phase 24V DC brushless (BLDC) motors to control its robotic nozzles. These are the same motors used in numerous industrial robots — and for good reason. BLDC motors offer numerous advantages over standard, “brushed” DC motors used in most competing products., such as higher torque, higher precision in their control, and much longer life.

Controlling BLDC motors, however, requires special electronics to precisely control the three phases sent to the motors. That's where Unifire's unique BLDC motor driver cards come in.

With Unifire's BLDC motor driver cards, our customers benefit from the highest precision steering and control of any robotic nozzle on the market —with an accuracy over over 1/50th of a degree.



ONE Graphical User Interface

ONE

App for iOS & Android

The First & Only Robotic Nozzle Control App on the Market, **ONE** is Unifire's revolutionary, full-functioned graphical user interface & virtual joystick for iOS & Android, available for free on Google Play Store and Apple iPhone App Store.



ONE

App for iOS & Android

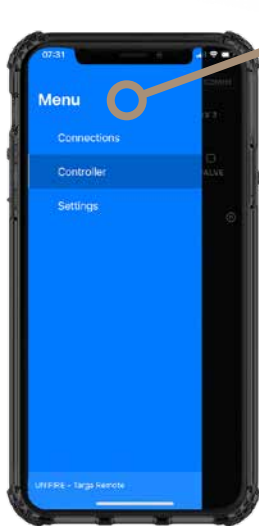

Intuitive Menu

Easily control your system
Connection, Settings or go to the
Control Screen.

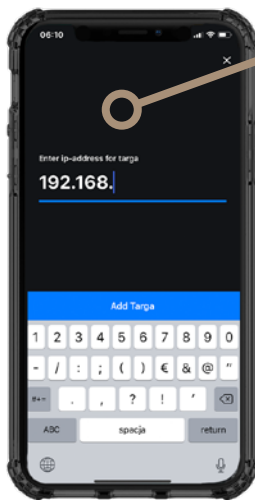

Simple Setup

Simply enter the IP Address of your
System Router for quick system
connection and control.

With Unifire's InterAct core technology and our ONE app, you no longer need a joystick.

For a fraction of the price of our competitors' tethered and wireless joysticks, you can turn any device into a powerful wireless controller. And, it's easier to use and comes loaded with more functions than most competing controllers!

UNIFIRE

Welcome to 21st Century robotic nozzle system control!

TECHNICAL SPECIFICATIONS

FORCE 50

REV. 2.2 2021-02-04

8-15

UNIFIRE FORCE 50 Robotic Nozzle
Installation and setup manual



π TM (Pi) CAN bus Joystick

CAN bus Progressive Speed, Full-Featured Joystick

Unifire's π (Pi) Joystick is Unifire's versatile, full-functioned, hand-held joystick for precise and intuitive control of Force robotic nozzles. Our most popular controller, it is robust and water resistant, with numerous features.

Specifications:

- Multifunctional CANbus joystick
- Intuitive, progressive speed control
- 3-Axis control (horizontal, vertical, nozzle)
- Nozzle spray pattern controlled by dial on tip of joystick shaft
- Record / Play - Record any sequence including velocity changes, pauses, & nozzle spray pattern. Play back in a continuous loop.
- Programmable park (stow) function
- LED Position Indicators for relative horizontal, vertical and nozzle positions
- Valve Control Button
- 2 auxiliary buttons for custom configuration & control of peripherals (e.g., lights).
- Up to 500 meter cable supported
- Hand-held
- Weighs only 1 Kg



**Seriously Heavy
duty!!
All chrome plated
brass and stainless
steel. Butter-smooth
action. Massively
supportive when the**

POINTER™ Synchron Joystick

Synchronized Movement of POINTER and Robotic Nozzle

The POINTER is Unifire's unique, synchron control device designed to provide a simple and intuitive human interface for controlling the Unifire's robotic nozzles.

The robotic nozzle's movements exactly follow and match the position of the POINTER.

The base is fitted with potentiometer to provide exact position values to the TARGA PLC, which in turn aim the robots to exactly the same horizontal and vertical angles as the POINTER. The hand-grip has a trigger switch at the front. The switch has a spring return. The switch will be connected directly to the vehicle's discharge valve. The water is discharged when the trigger is held, and stops when the trigger is released.

Specifications:

- 142 x 130 x 70 mm (above the panel into which it is mounted)
- Material: Chrome plated brass base; heavy duty plastic grip cover on a 4 mm stainless steel plate
- 5-pin M12 connector connect to the TARGA PLC
- 3-pin M12 connector to route the trigger button to discharge valve control
- Standard rotation range: +70°/-20° vertical, 270° horizontal
- Scroll wheel option for progressive jet/spray nozzle tip control



BLDC Motors

& Complete Motor Can Assemblies

Motor Features

Where our competitors are still using run-of-the-mill “brushed” DC motors (which have been used since 1856), Unifire alone is blazing new trails by outfitting all of our robotic nozzles with industrial-robot-type brushless DC (BLDC) motors.

Brushless DC motors have no brushes to get worn out, they have significantly higher efficiency and performance, and a lower susceptibility to mechanical wear than standard brushed motors. Some of the other advantages include:

- Higher torque to weight ratio
- Increased torque per watt of power input (increased efficiency)
- Increased reliability and lower maintenance
- Reduced operational and mechanical noise
- Significantly longer life span (10 000 operational hours)

Although it is highly unlikely to ever require replacing a BLDC motor in our robotic nozzles, we do stock and can supply spare motors and complete motor can assemblies with motors pre-assembled for simple, quick replacement.

FORCE 50 SPARE PARTS



Force 50 Complete Worm Gear Assembly

Complete worm gear assembly with gear wheel, gear screw, bearings, and O-ring. Connected to the pipes by flange assembly.

Part Number.: FOR50200

Complete BLDC Motor & Welded Cover

BLDC Motor in threaded stainless steel cover, for quick and simple motor replacement.

Part Numbers.:

BLDC84S (Vertical motor assembly)

BLDC49S (Horizontal motor assembly)

1621962: BLDC with 49:1 Gear Ratio

1621963: BLDC with 84:1 Gear Ratio



Force 50 Front Pipe Section

Front pipe section for the Force 50, with stream straightener and 2" BSP male thread outlet for nozzle tip connection.

Part Number.: FORCE50-PS1



Force 50 Middle Pipe Section

Force 50 middle pipe section with flange connection with 10 x (M5x16) at both ends.

Part Number.: FORCE50-PS2



Custom Solutions



Horizontal Swing Arm

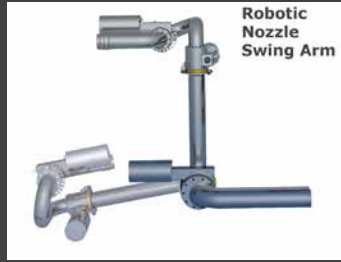

Vertical Swing Arm



Automatic Doors



Flange Connection



Vehicle Side Turret



Telescopic Pipe



Custom Radio Remote



Force 50 Rail Mount



Force 80 Rail Mount

Unifire offers a variety of piping mounts, swing arms, automatic doors, special vehicle solutions (including touchscreen computer controls) and other custom solutions.

Pictured above are just a few examples. If you have special requirements, contact us for more information.